

ICEpower250ASP

250W Professional ICEpower Amplifier with ICEpower Supply

Version 1.6

Contents

General Description	2
Release Notes	3
Block Diagram	4
Connection Diagram	4
Absolute maximum ratings	6
Power Specifications	7
Audio Specifications	7
Electrical Specifications	8
Timing Specifications	8
Thermal Specifications	8
Disturbances on the Mains	9
Mechanical Specifications	9
Typical Performance Characteristics	10
Efficiency vs. Output Power	15
Loading	16
Features	16
Protection Features	18
Input/Output Interfaces	19
Thermal Design	21
Fuses	21
Physical Dimensions	22
Safety Standards	25
ESD Warning	25
Packaging and Storing	25
Contact	26
Legal Notes	26

General Description

ICEpower250ASP is a high quality audio power solution capable of generating 250W RMS output directly from selectable 115/230 volt mains.

The ICEpower250ASP integrates the conventional power supply and amplifier into one highly compact and lightweight solution with state-of-the-art performance.

Applications include:

- Active speakers and subwoofers
- Installation audio products
- High-end stereo and multi-channel amplifiers



Figure 1: ICEpower250ASP .Size: 15 cm x 16.3 cm x 5.2 cm

For full range multi-way or multi-channel applications up to two additional ICEpower250A amplifiers may be powered from the DC-bus connector. The ± 12 volt outputs of the ICEpower250ASP also provide general purpose auxiliary supplies for external circuitry.

The aluminum extrusion includes slots that accept 3mm thread forming screws for easy mounting to any chassis or back plate. The ICEpower250ASP is protected against short-circuits, overload and over-heating and the on-board fuse and EMI filtering provides a CE and FCC approved design.

Key Specifications

- 250W @ 0.01% THD+N, 1kHz, 2.7 Ω
- 300W @ 1% THD+N, 1kHz, 2.7 Ω
- 112dBA dynamic range
- Max output voltage / current: 45V_p / 25A_p, 4 Ω
- THD+N < 0.08%, 0.1W – 170W, 4 Ω
- Bandwidth limit = 80 kHz (8 Ω)
- Total efficiency 83 % @ 100W, 8 Ω
- Stand-by power dissipation typically 2W
- Mains connection is class 1 (with earth)

Key Features

- Very rugged construction for professional use
- Comprehensive protection scheme
- Suitable for CE approved designs
- Power output for ICEpower250A
- ± 12 volt auxiliary output
- Selectable mains 115/230Vac
- Safety conforms to: UL/IEC 60065 and others
- EMI conforms to: EN55103-1
EN55103-2
FCC part 15b Class A

Release Notes

Version	Date	Revised by	Changes
1.6	2017-09-07	LBH/DIT	Output voltage / current spec. added Safety and EMI standards updated Address updated Legal Notes updated

Block Diagram

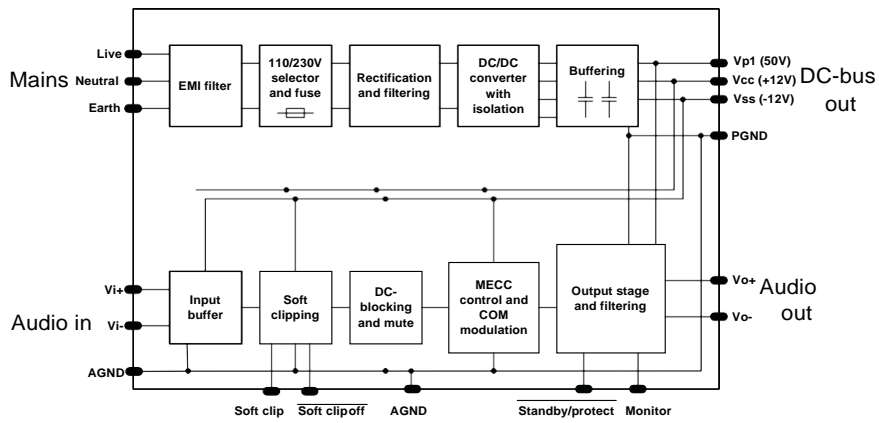

Figure 2: ICEpower250ASP block diagram

Connection Diagram

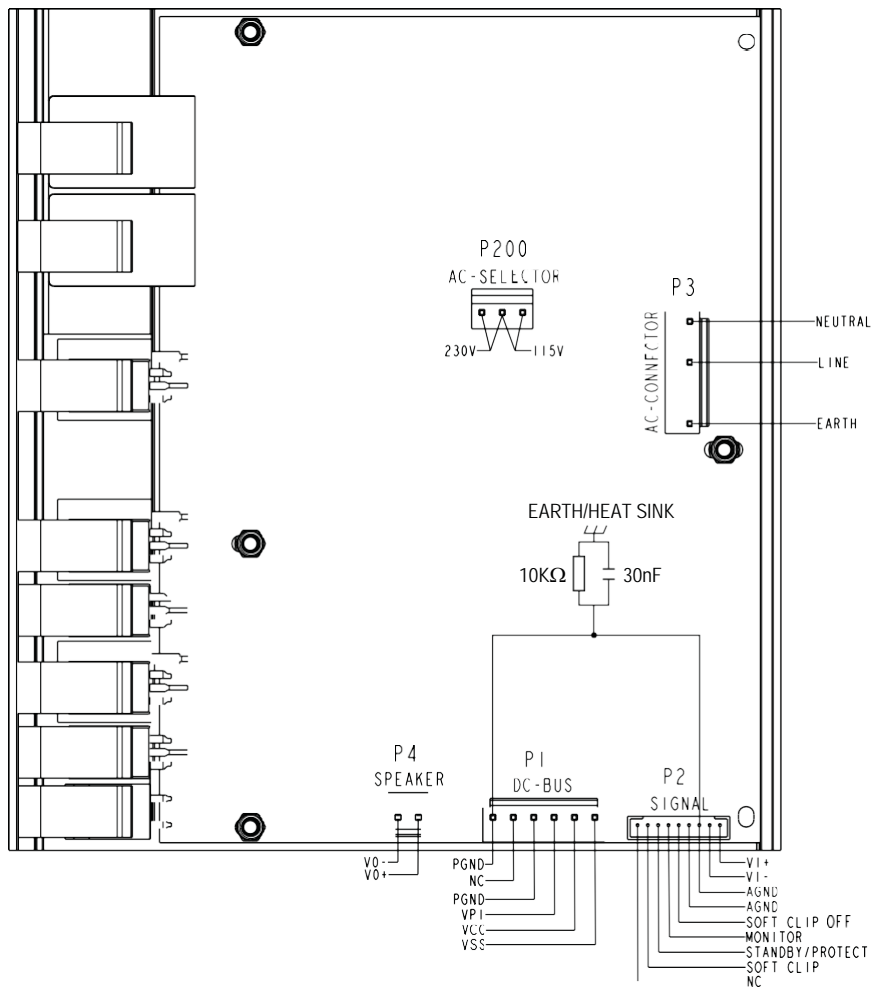

Figure 3: ICEpower250ASP connections

The plug interface of the ICEpower250ASP modules has four industry standard connectors selected for long-term reliability.

AC Connector Specification (P3)

The ICEpower250ASP is Class 1 equipment and therefore must have an earth connection.

Type: JST B3(6-2,4,5)P-VH			
PIN	Function	Description	Type
1	Neutral	Neutral AC	Input
2	Line	Phase AC	Input
3	Earth	Safety earth connection	GND

Table 1: AC connector specification

AC Selector Specification (P200)

Type: Jumper			
PIN	Function	Description	Type
1-2	115V _{AC}	115V _{AC} mains voltage	Internal
2-3	230V _{AC}	230V _{AC} mains voltage	Internal

Table 2: AC selector specification

Signal Connector Specification (P2)

Type: JST 9-pole PH-connector			
PIN	Function	Description	Type
1	Earth	Connected directly to mains earth.	Earth
2	Soft clip	Soft clip indication (open collector).	Output
3	Standby/protect	Control pin for standby control (Internal pull-up).	Input & Output
4	Monitor	Unbalanced attenuated output signal.	Output
5	Soft clip off	Control pin for disabling the soft clipping circuit.	Input
6	AGND	Ground terminal for the signal section.	GND
7	AGND	Ground terminal for the signal section.	GND
8	Vi-	Negative input (balanced input buffer).	Audio Input
9	Vi+	Positive input (balanced input buffer).	Audio Input

Table 3: Signal connector specification.

DC-bus Connector Specification (P1)

Type: JST 6P-VH-B			
PIN	Function	Description	Type
1	PGND	Power supply Ground	GND
2	NC	No connection	
3	PGND	Power supply Ground	GND
4	Vp1 (50V)	Power supply 50V	Output
5	Vcc (+12V)	Power supply +12V	Output
6	Vss (-12V)	Power supply -12V	Output

Table 4: DC-bus connector specifications.

Speaker Connector Specification (P4)

Type: JST 2P-VH-B			
PIN	Function	Description	Type
1	Vo+	" Hot " balanced audio power output terminal.	Output
2	Vo-	" Cold " balanced audio power output terminal.	Output

Table 5: Speaker connector specifications.

Absolute maximum ratings

Absolute maximum ratings indicate limits beyond which damage may occur.

Mains Input Section

Symbol	Parameter	Value	Unit
AC_{max}	Maximum off-line voltage 115V _{AC} setting Maximum off-line voltage 230V _{AC} setting	132.5 265	V _{AC}
AC_{min}	Minimum off-line voltage 115V _{AC} setting Minimum off-line voltage 230V _{AC} setting	90 ¹⁾ 190 ¹⁾	V _{AC,60Hz} V _{AC,50Hz}
f	Mains frequency range 115V _{AC} Mains frequency range 230V _{AC}	55 – 65 45 - 55	Hz Hz
$I_{fuse}^{2)}$	Fuse rating 115V Fuse rating 230V	T3.15 T2.5	AH AH

Table 6: Absolute maximum ratings mains input section.

1) The ICEpower250ASP will operate at lower levels but the output power will be reduced. If the off-line voltage is too low the ICEpower250ASP switches off.

2) See fuses section for details.

DC-Bus

Symbol	Parameter	Value	Unit
$I_{50V}^{3)}$	Maximum current draw from Vp1 (50V)	5.5	A
$I_{+12V}^{4)}$	Maximum current draw from Vcc (+12V)	0.8	A
$I_{-12V}^{4)}$	Maximum current draw from Vss (-12V)	-0.8	A

Table 7: Absolute maximum ratings, DC-bus.

3) The stated value is the maximum current available from the power supply when the internal amplifier is idle. Note that this power bus is only intended for use with other ICEpower amplifiers as shown in the ICEpower ASP-series Designer's Manual.

4) The +/-12V outputs are not short circuit protected and must be fused to avoid damage. See the ICEpower ASP-series Designer's Manual.

Input Section

Symbol	Parameter	Value	Unit
Vin+ , Vin-	Maximum voltage range on pin	±12	V
Standby/protect	Maximum voltage range on pin	0-12	V
Soft clip off	Maximum voltage range on pin	0-12	V

Table 8: Absolute maximum ratings, input section.

Output Section

Symbol	Parameter	Value	Unit
R_{load}	Minimum load	2	Ω
C_L	Maximum purely capacitive load	470	nF
Soft clip	Maximum voltage range on pin	0-12	V
Monitor	Maximum voltage range on pin	+/-12	V

Table 9: Absolute maximum ratings, output section.

5) The over current protection will act to protect the amplifier. (See "Protection Features")

Thermal Section

Symbol	Parameter	Value	Unit
T_a	Max. operating ambient temperature	50	°C

Table 10: Absolute maximum ratings, thermal section.

Power Specifications

Unless otherwise specified. $T_a=25\text{ }^\circ\text{C}$, $f=1\text{kHz}$, $\text{Load}=4\Omega$.

Symbol	Parameter	Conditions	Min	Typ	Max	Unit
V_{p1}	Nominal DC voltage 1	Off-line input within range	-	50	-	V
V_{cc}	Positive analog supply	Off-line input within range	-	12	-	V
V_{ss}	Negative analog supply	Off-line input within range	-	-12	-	V
I_{Pmax}	Time of maximum rated output power	250W out. No preheating.	-	60	-	s
P_T	Continuous output power ⁶⁾ without thermal shutdown.	Thermal stab. @ $T_a = 25\text{ }^\circ\text{C}$. 4 Ω , no external heatsink.	-	90	-	W
P_T	Continuous output power ⁶⁾ without thermal shutdown.	Thermal stab. @ $T_a = 50\text{ }^\circ\text{C}$. 4 Ω , no external heatsink.	-	35	-	W
P_{FTC}	FTC rated output power 0-5kHz ⁷⁾	4 Ω , No external heatsink	-	200	-	W
P_q	Quiescent power dissipation	$P_o = 0W$	-	7.5	-	W
P_{stby}	Stand-by power dissipation	Amplifier disabled	-	2	-	W
η	Power Efficiency (4 ohm load)	$P_o = 200W$, 230V mains $P_o = 100W$, 230V mains	-	83 79	-	%

Table 11: Power specifications

6) The module is mounted vertically in free air. Continuous output power can be improved by the means of external heat sink or forced convection.

7) The power bandwidth is limited to protect the output Zobel network.

Audio Specifications

Unless otherwise specified, $f=1\text{kHz}$, $P_o=1W$, $T_a=25\text{ }^\circ\text{C}$, soft clip enabled.

Symbol	Parameter	Conditions	Min	Typ	Max	Unit
$P_{O,max}$	Output power @ 1%THD+N 10Hz < f < 20kHz (AES17 measurement filter) ⁸⁾	$R_L = 2.7\Omega$.	-	300	-	W
		$R_L = 4\Omega$.	-	250	-	W
		$R_L = 8\Omega$	-	130	-	W
V_{o-max}	Max output voltage	$R_L = 4\Omega$	-	45	-	V_p
I_{o-max}	Max output current	(output current limited)	-	25	-	A_p
THD+N	THD+N in 4 Ω (AES17 measurement filter) ⁸⁾	$f = 1\text{kHz}$, $P_o = 1W$	-	0.0055	0.01	%
THD+N	Maximal THD+N in 4 Ω (AES17 measurement filter) ⁸⁾	10Hz < f < 20kHz 100mW < P_o < 200W	-	0.1	0.12	%
$V_{N,O}$	Output referenced idle noise	A-weighted 10Hz < f < 20kHz	70	80	100	μV
A_V	Nominal Voltage Gain	$f = 1\text{kHz}$	26.7	27.0	27.3	dB
f	Frequency response	20Hz - 20kHz, All loads	-	+0.3/ -0.5	+0.8/ -1.0	dB
f_u	Upper bandwidth limit (-3dB)	$R_L = 8\Omega$	-	80	-	kHz
		$R_L = 4\Omega$	-	60	-	kHz
f_l	Lower bandwidth limit (-3dB)	$R_L = 8\Omega$	-	5.3	-	Hz
		$R_L = 4\Omega$	-	5.3	-	Hz
Z_o	Abs. output impedance	$f = 1\text{kHz}$	-	5	10	$m\Omega$
Z_L	Load impedance range		2	4	\equiv	Ω
D	Dynamic range	A-weighted at 200W @ 4 Ω	109	111	112	dB
IMD	Intermodulation (CCIF)	$f = 14\text{kHz}$, 15kHz, $P_o = 10W$	-	0.0009	-	%
TIM	Transient intermodulation (TIM)	$f_1 = 3.15\text{kHz}$ square, $f_2 = 15\text{kHz}$, $P_o = 10W$	-	0.003	-	%

Table 12: Audio specifications.

8) An Audio Precision AES17 20kHz 7th order measurement filter is used for measurements. The frequency 6.67 kHz corresponds to the worst-case situation where both 2nd and 3rd harmonics are within the audio band.

Electrical Specifications

Unless otherwise specified, $T_a=25\text{ }^{\circ}\text{C}$.

Symbol	Parameter	Conditions	Min	Typ	Max	Unit
f_o	Idle switching frequency	Idle	350	400	450	kHz
f_s	Switching frequency range	Idle to full scale variation	70		450	kHz
f_{smps}	Switching frequency power supply		-	100	-	kHz
$V_{\text{OFF,Diff}}$	Differential offset on output terminals	Input terminated	-	-	± 50	mV
$V_{\text{OFF,CM}}$	Common mode offset on output terminals	Input terminated	-	25	-	V

Table 13, Electrical specifications

Timing Specifications

Symbol	Parameter	Conditions	Min	Typ	Max	Unit
t_{acd}	Power supply start up delay.	Time from AC_{min} to all power supplies are good.	-	500	-	ms
t_{sd}	Switching start up delay	Time from all power supplies are good to startup	-	1200	-	ms
$t_{\text{psd}}^{9)}$	Shutdown delay	Supply fail or Standby pin	-	200	-	μs

Table 14, Timing specifications.

9) Only valid with the circuit shown in Figure 16.

Thermal Specifications

Symbol	Parameter	Conditions	Min	Typ	Max	Unit
$R_{\text{th, sink-a}}$	Thermal resistance, heatsink – ambient			1.6		K/W

Table 15: Thermal specifications

Disturbances on the Mains

The signal on the mains connection is often very noisy and large surge voltages are present. The ICEpower250ASP is equipped with mains filtering to suppress surges and noise.

Lightning

To avoid damage of the ICEpower250ASP in case of surges caused by lightning, special care and component selection have resulted in capability of withstanding surges up to 8kV. (Tested with surge generator meeting IEC1000-4-5 at 8kV).

Mechanical Specifications

During development, the ICEpower250ASP has been exposed to tough mechanical tests to ensure reliable performance in even the most demanding professional applications.

Test	Acceleration	Amount
Unpowered tests: The unit is powered after the test to verify functionality.		
Random vibration	2g _{RMS}	3x20min
Bump	10g/16ms, 2-4 Hz	1000 bumps in each of 6 directions ¹⁰⁾
Shock	70g/12ms	3 shocks in each of 6 directions ¹⁰⁾
Powered tests: The unit is tested with power applied.		
Sinusoidal vibrations	2.5mm, 5-10Hz 1g, 10-100Hz	2 hours in each of 3 directions ¹⁰⁾
Random vibrations	0.01g, 10-20Hz 0.7g _{RMS} -3dB/oct, 20-150Hz	2 hours in each of 3 directions ¹⁰⁾

Table 16: Mechanical tests

¹⁰⁾ 6 directions: (up, down, left, right forward and backward). 3 directions: (up and down, left and right, forward and backward)

Typical Performance Characteristics

Frequency Response

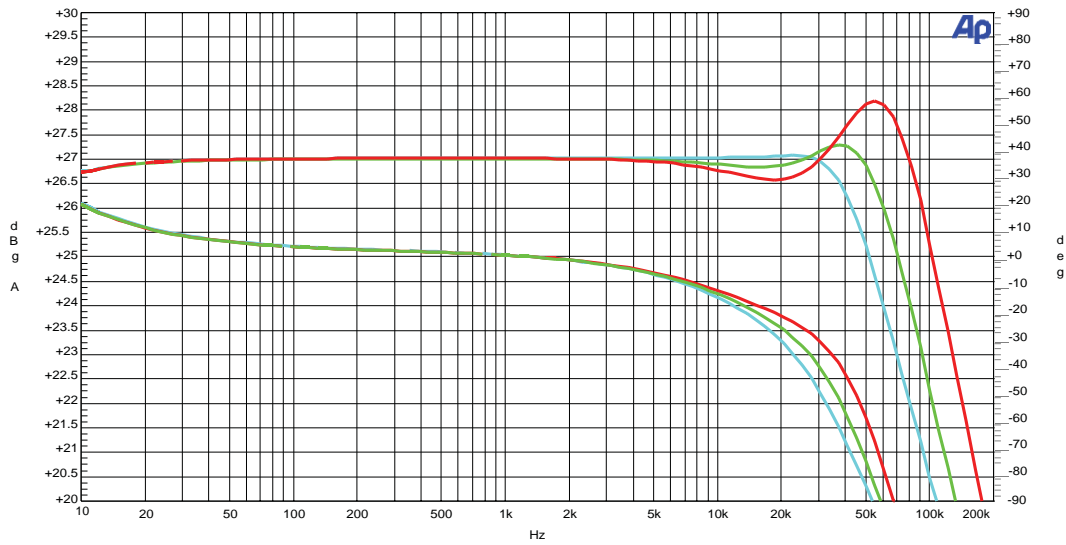

Figure 4: Frequency response in 4Ω, 8Ω and open load. Top – amplitude. Bottom – phase.

Output Impedance

The output impedance is measured by feeding 1A_{RMS} into the output of the amplifier and measuring the voltage on the output. The output impedance then corresponds to the measured voltage.

The measurement is done at three different points to illustrate the impedance of connectors and wires. The curve showing the lowest impedance is measured directly on the PCB. The next curve is measured at the terminals of the ICEpower application connector. The curve showing the highest impedance is measured at one pair of the four banana plugs on the ICEpower application connector (10cm wire).

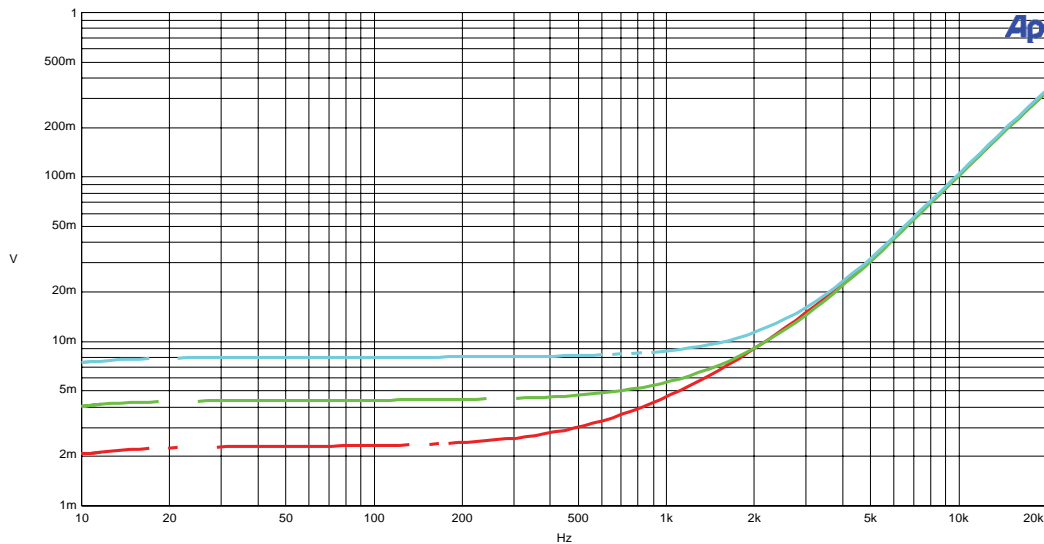

Figure 5: Measured voltage at output terminals while feeding 1A_{RMS} into the output of the amplifier.

Damping Factor

The damping factor is calculated as the ratio between the output impedance and the load impedance. The three curves relate to the different curves of the output impedance.

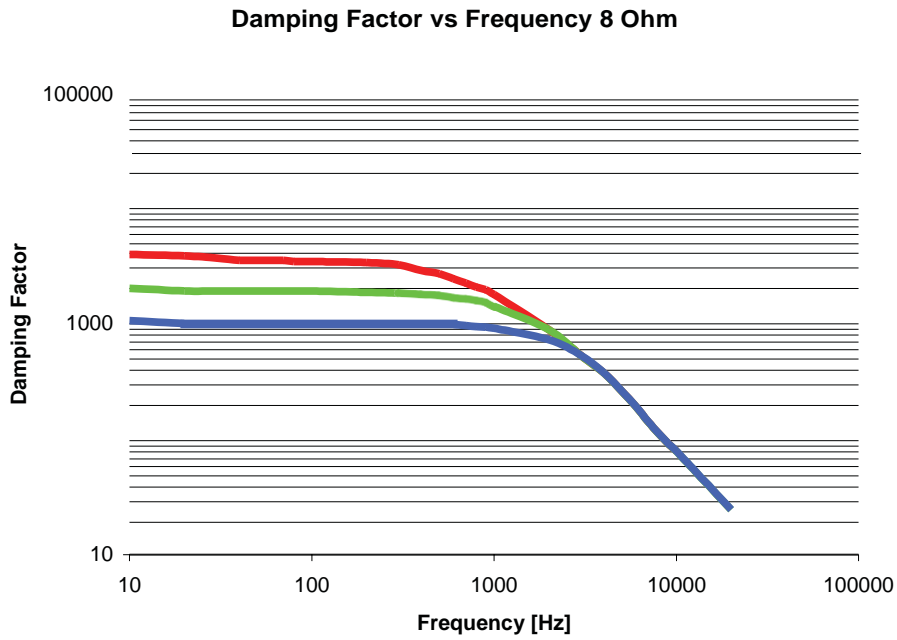

Figure 6: Damping factor vs. frequency 8Ω.

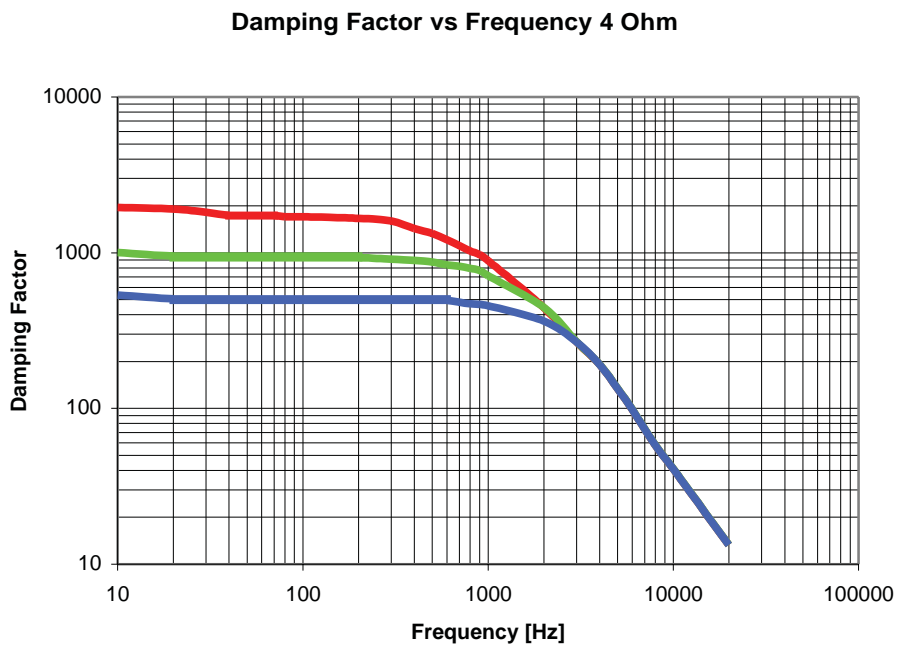

Figure 7: Damping factor vs. frequency 4Ω.

S/N Ratio vs. Power Output

The signal to noise ratio depends on the chosen "signal" output power in relation to the idle noise floor. When the output signal level is equal to the maximum output power of the amplifier the S/N ratio is equal to the dynamic range of the module.

S/N ratio vs output power

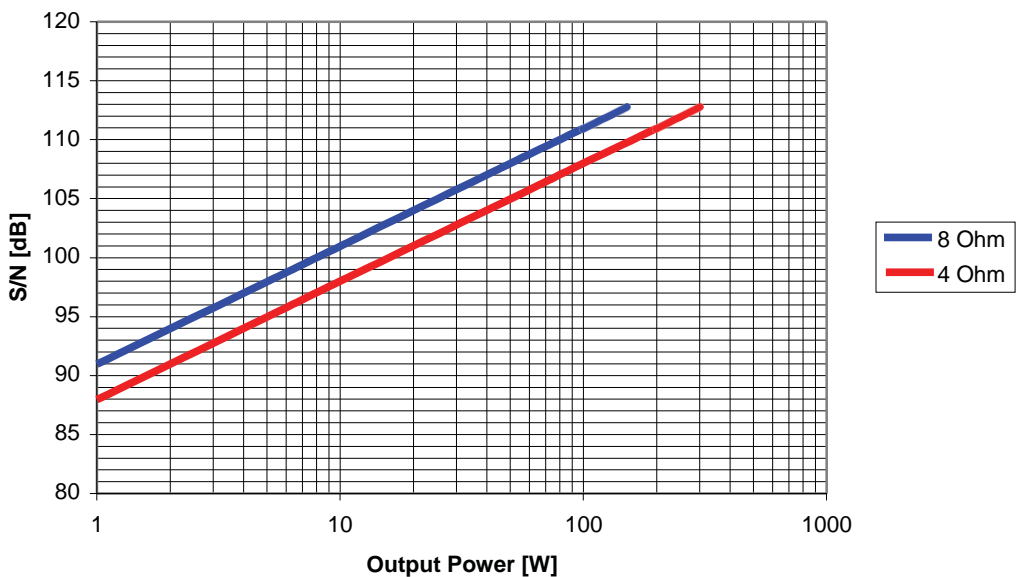
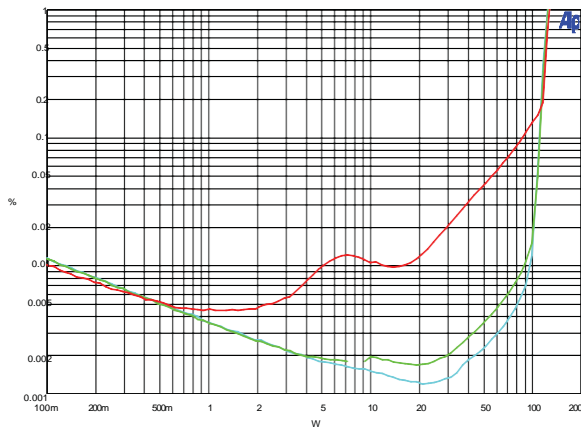
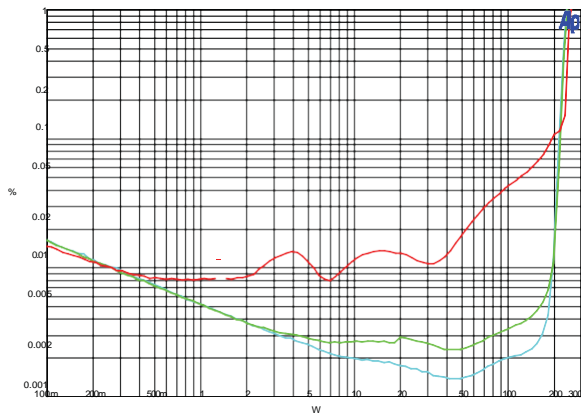

Figure 8: S/N vs. output power

Harmonic Distortion & Noise



THD+N vs. output power at 100Hz, 1kHz and 6.67kHz ⁴⁾ (8Ω).



THD+N vs. output power at 100Hz, 1kHz and 6.67kHz ⁴⁾ (4Ω).

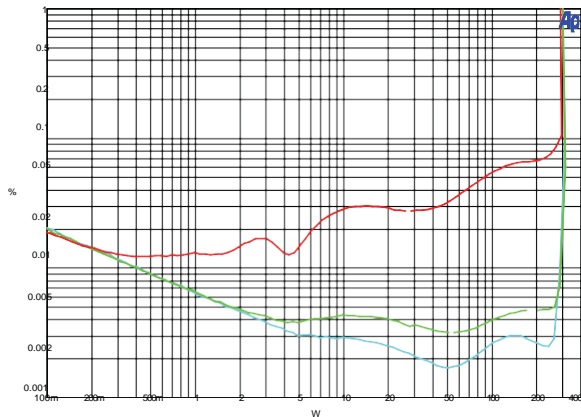

THD+N vs. output power at 100Hz, 1kHz and 6.67kHz ⁴⁾ (2.7Ω).

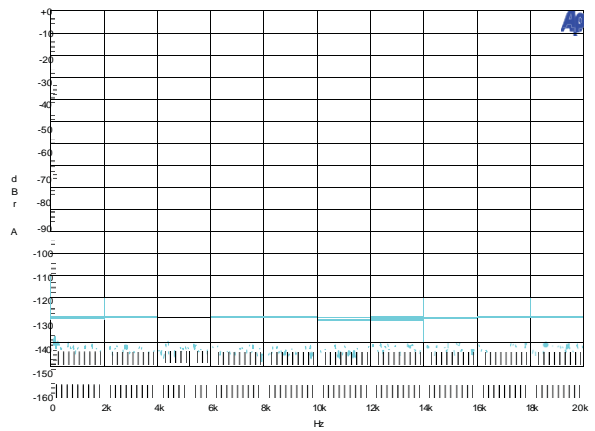

Idle noise (16K FFT). Residual = 80µV(A).

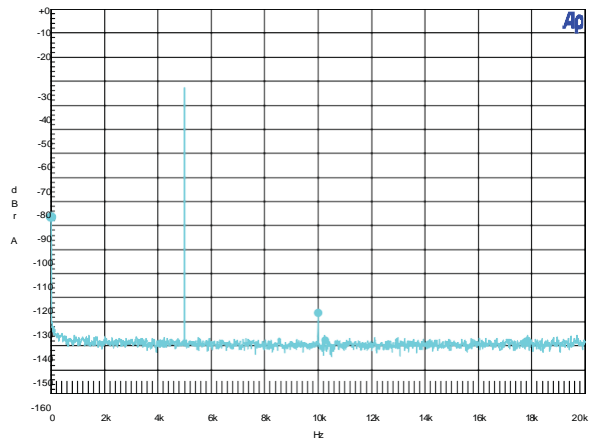

f = 5kHz. P_o = 100mW. 4Ω loading. THD = 0.003%.

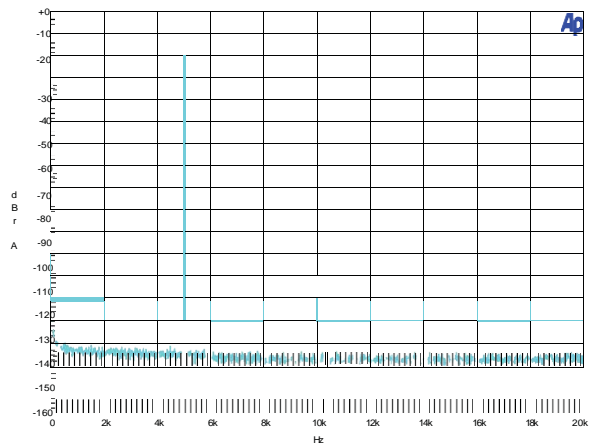

f = 5kHz. P_o = 1W. 4Ω loading. THD = 0.0045%.

Figure 9: Total harmonic distortion & noise.

4) An Audio Precision AES17 20 kHz 7th order measurement filter is used for measurements. The frequency 6.67 kHz corresponds to the worst-case situation where both 2nd and 3rd harmonics are within the audio band.

Intermodulation Distortion (CCIF, SMPTE & TIM)

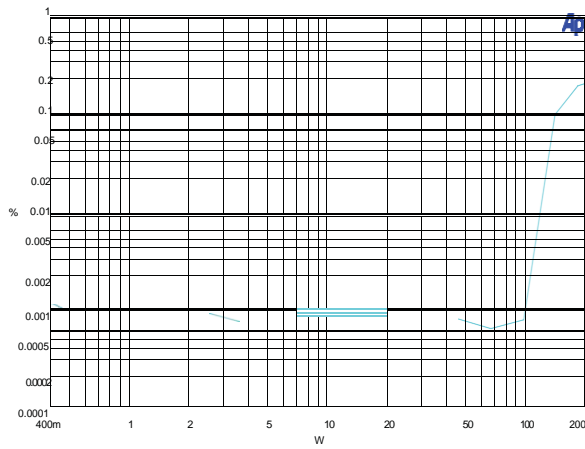

CCIF IMD vs. P_o , $R_L = 4\Omega$, $f_1 = 14\text{kHz}$, $f_2 = 15\text{kHz}$.

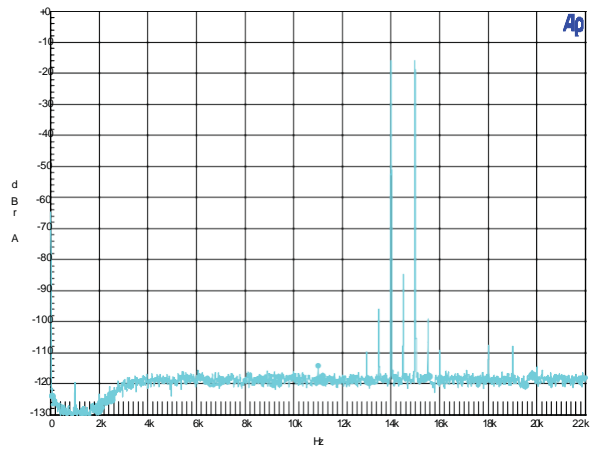

CCIF IMD analysis. $R_L = 4\Omega$, $P_o = 10\text{W}$, $\text{IMD} = 0.0009\%$.

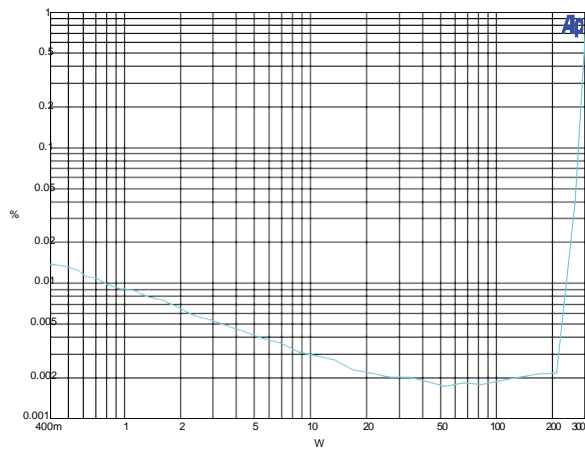

TIM vs. output power. $R_L = 4\Omega$.

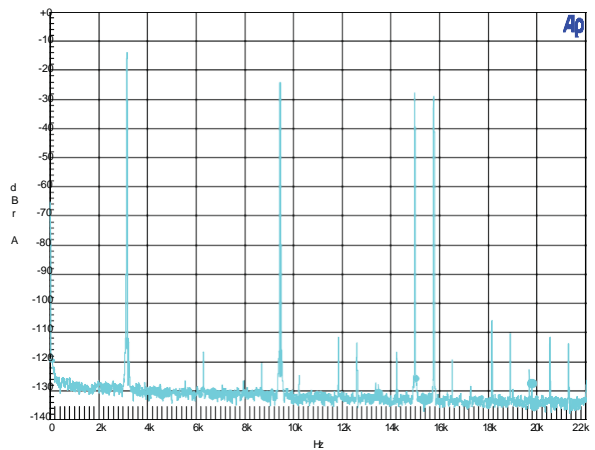

TIM FFT analysis. $R_L = 4\Omega$, $P_o = 10\text{W}$, $\text{TIM} = 0.003\%$

Figure 10: Intermodulation distortion

Power Bandwidth

Due to the compensating Zobel network in the output stage, the maximum allowable short-term output power is frequency-dependant. The short-term output power is defined as the maximum undistorted (THD+N < 0.1%) output power until thermal shutdown occurs. Note that long-term high power levels may be limited by other safety circuits before the HF long-term power limit is reached.

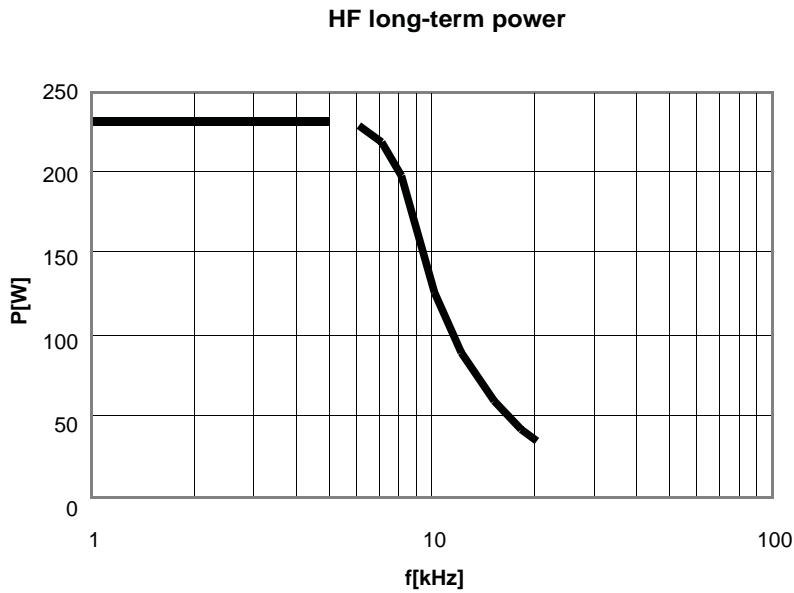

Figure 11: HF long-term output power

Due to the HF protection circuit the amplifier is only able to deliver full output at high frequencies for a short time.

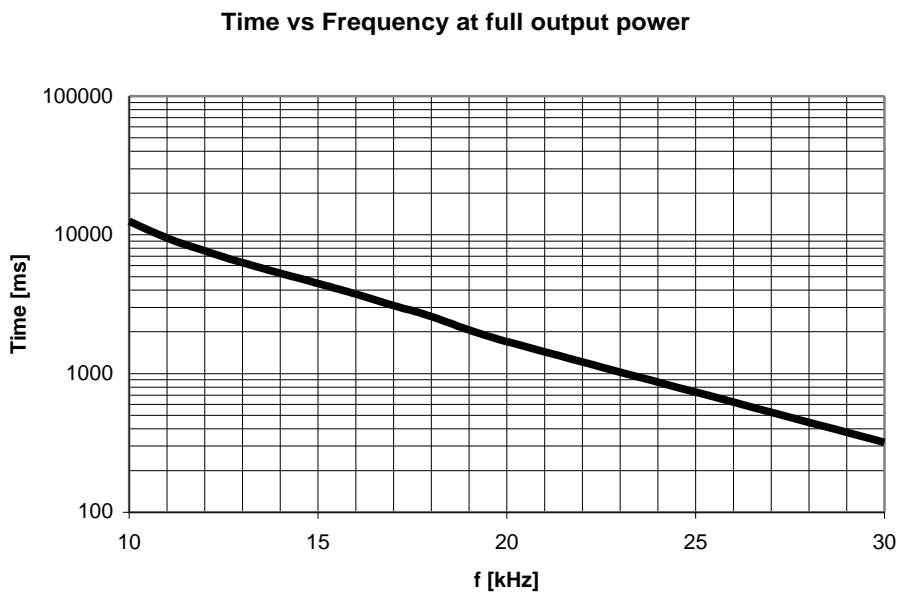

Figure 12: Duration of full output vs. frequency

Efficiency vs. Output Power

The total power conversion efficiency is calculated as the ratio between the audio output power and the power consumed from the mains.

ICEpower250ASP efficiency 8 Ohm

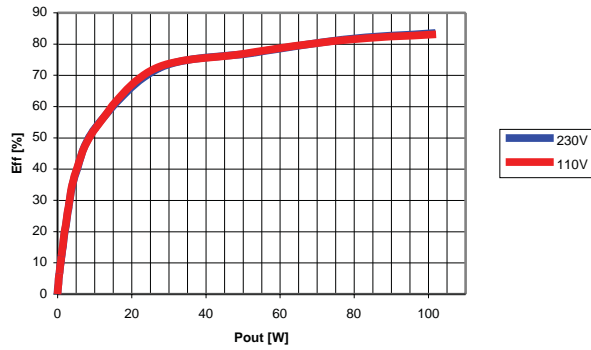

Figure 13: Efficiency vs. output power (8Ω load, 1 kHz audio).

ICEpower250ASP efficiency 4 Ohm

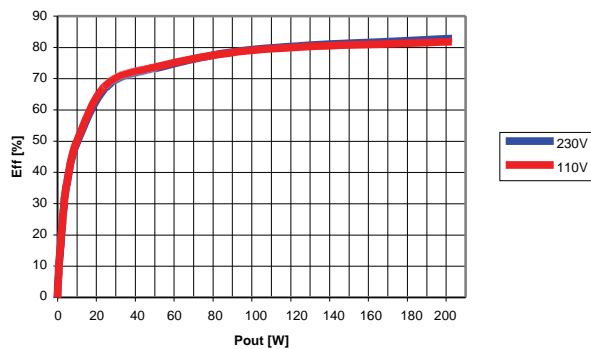

Figure 14: Efficiency vs. output power (4Ω load, 1 kHz audio).

ICEpower250ASP efficiency 2.7 ohm

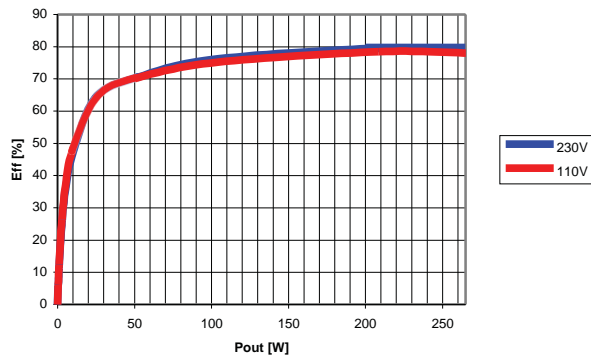

Figure 15: Efficiency vs. output power (2.7Ω load, 1 kHz audio).

Loading

With its low output impedance, the ICEpower250ASP is designed to be unaffected by loudspeaker loading characteristics. However, care should be taken with *purely* capacitive loads.

Traditionally amplifiers have been tested extensively in laboratories with purely capacitive loads. This was done to test the amplifier's stability and performance but it does not relate to any normal speaker load as even electrostatic speakers do not present a purely capacitive load to the amplifier but include a resistive part as well. The maximum purely capacitive load allowed is 470nF.

Features

The ICEpower250ASP has a number of useful features as described below.

Standby/Protect Control

The Standby/protect pin is pulled low internally when the protection circuits activates. It is also possible to pull the pin low externally to activate the low power consumption mode.

The recommended external circuit for shutdown is shown in Figure 16. The timing specifications are only valid with the interface circuit shown in Figure 16.

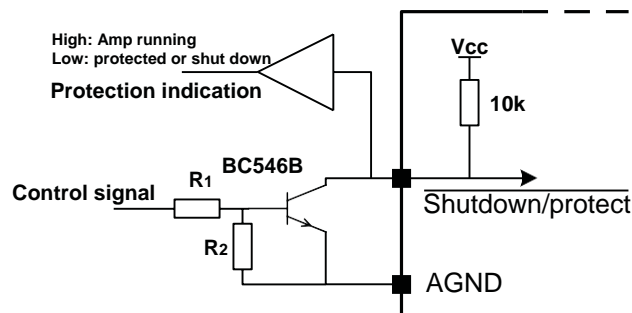

Figure 16: Interface and simplified internal circuit for Shutdown/protect pin.

Monitor Output

The monitor output has been implemented as an attenuated ground referenced (unbalanced) version of the balanced output signal. The internal output circuit of this output is shown below.

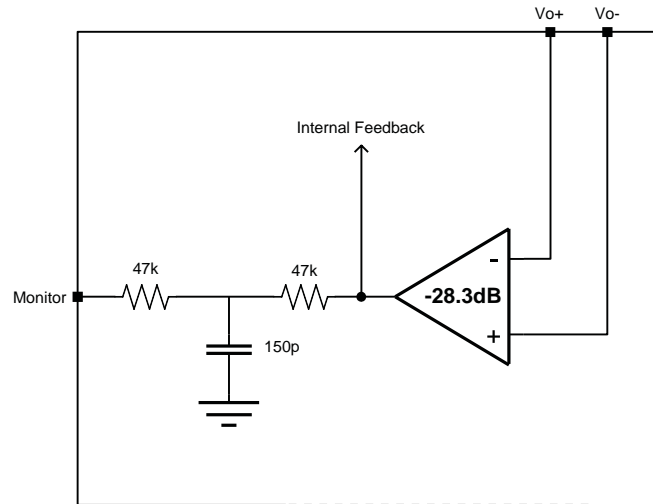

Figure 17: Internal circuitry of the monitor output.

The monitor output is attenuated 1.3dB in relation to the input signal and the bandwidth is limited to 45 kHz.

Soft clipping and Clipping Detection

The ICEpower250ASP is equipped with a soft clipping circuit that shapes the input signal softly and limits the maximum signal level to the output stage. The soft clipping system eliminates saturation of the control system for optimum sound performance in high-level situations.

The Soft clip pin is an open collector output with a series resistor for connecting directly to an LED or external processing circuits. The internal circuit is shown in Figure 18.

Soft-clip off

The Soft clip off pin disables the internal soft clipping circuit when pulled low. This allows for use of external clipping circuits to suit the application without interference from the internal circuit.

Even with the Soft clip off pin set to low the protection features still activate the internal circuit.

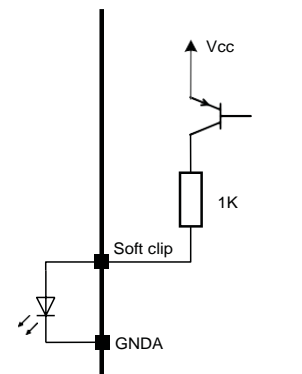

Figure 18: Interface and simplified internal circuit for the Soft clip pin.

Protection Features

The ICEpower250ASP is equipped with professional protection features for surviving in the rough professional audio environment without damage and without compromising the audio quality.

Generally the protection circuits are designed with the philosophy of “audio all time” in mind and therefore all protection circuits are self-resetting. The only circuit that does not reset is the ‘HF on output’ circuit that only activates in case of a failure or large capacitive load.

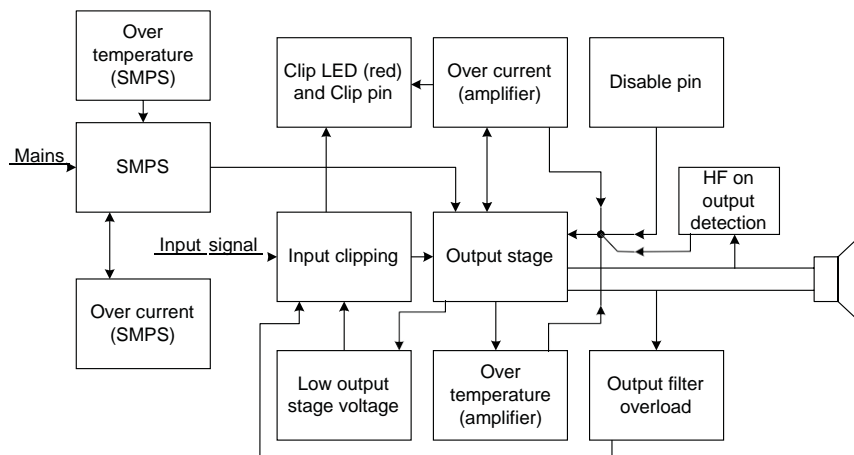

Figure 19: Block diagram of protection features

Over current protection

The over current protection is designed with two states. The first state limits the output current to the protection level of 25A. This level of current is allowed for a short period of time, but if the output current remains too high, state two is activated. State two disables the amplifier for the same amount of time as if a power failure had occurred. The amplifier will restart when the cause of the overload has been removed, and in case of short overloads, the music will continue playing.

Thermal Protection

The ICEpower250ASP is equipped with two thermal protection circuits. The first monitors the temperature of the power supply and attenuates the output voltage if the temperature exceeds the limit. The other protection circuit monitors the amplifier temperature and shuts down the amplifier if the temperature becomes too high. Both protection circuits are self-resetting once the temperature has dropped to an acceptable level.

Overload Protection

In case of high-amplitude continuous low frequency signals in loads lower than 2.7Ω the power supply may not be able to deliver the required amount of power to the amplifier and the supply voltage will drop. The overload protection circuit will then lower the threshold of the input soft clipping circuit until the output power has been reduced to an acceptable level. As a result the amplifier will not shut down because of under voltage and the music will still be playing but with a softly shaped audio signal.

Long-term HF Protection

The output filter of the amplifier is not capable of handling large long-term high frequency signals due to the Zobel-network. This protection circuit decreases the threshold of the soft clipping circuit to limit the input signal in case of overload. Consequently, damage to the Zobel-network (or a high frequency driver) should not occur even under laboratory tests or any other condition that is not music (e.g. microphone feedback). The ICEpower250ASP has been tested at extreme levels with the most demanding music without triggering the high frequency protection circuit.

Input/Output Interfaces

Input Stage

The balanced input section on the ICEpower250ASP provides signal buffering and anti-aliasing filtering. The balanced configuration helps to avoid hum and noise pick-up in poorly shielded cables. An unbalanced input can be set (without affecting the overall gain) by applying a short between Vi- and AGND.

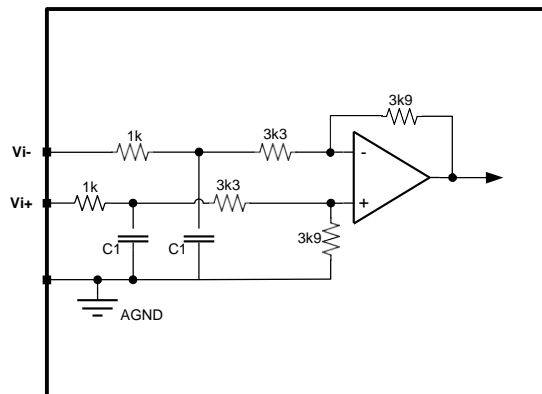

Figure 20: Balanced input buffer.

The input impedance of the signal input section is approximately $8k\Omega$ over the audio bandwidth, which is an acceptable loading condition for most pre-amps, active crossover outputs etc.

Output Stage

The output stage is a full bridge topology with a 2nd order filter meaning the power output on the terminals Vo+ and Vo- is balanced. The output filter design is a part of ICEpower's proprietary MECC topology and has been chosen as a compromise between demodulation characteristics, efficiency and filter compactness.

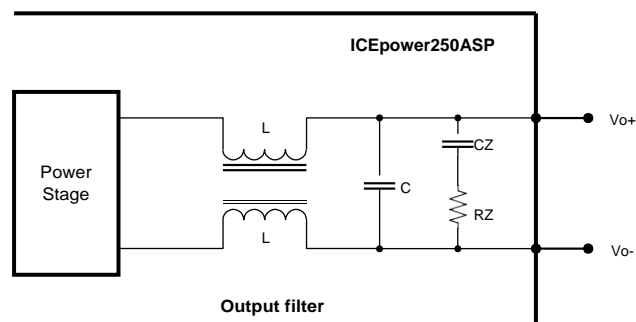

Figure 21: Output filter section with compensating Zobel network.

The essential output characteristics are:

- The switching residual on the output primarily consists of a single frequency component at the carrier fundamental f_s .
- The system bandwidth is 60 kHz in 8Ω .

Warning! The balanced speaker outputs are both “hot” with a common-mode DC level equal to $V_p/2$. Balanced probes should always be used for monitoring and measurements.

Operational Timing Diagram

The mains voltage and standby/protect pin control the ICEpower250ASP. If the mains voltage is below its minimum value the module will enter standby mode. The amplifier can be forced into standby mode by pulling the standby/protect pin low.

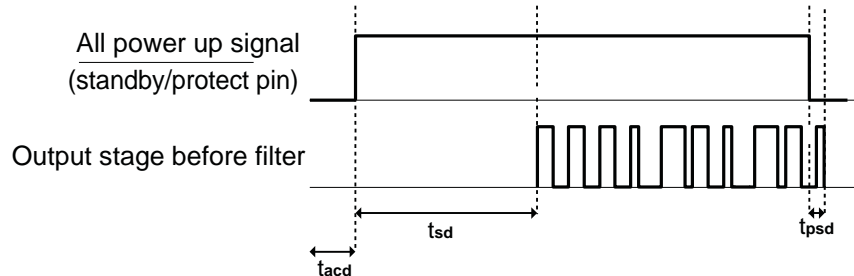

Figure 22: Supply start-up and shutdown timing definitions.

Power-up Sequence

The power supply controls power-up of the ICEpower250ASP. The power supply section has a delay (t_{acd}) from the mains voltage reaches the minimum value to all output voltages are up. In order to ensure power supply stability before start-up, a controlled delay (t_{sd}) has been introduced before the switching output stage is enabled with a 50% duty-cycle (zero modulation). Thus the total delay from power is applied to full signal amplification is $t_{acd} + t_{sd}$.

Power-down Sequence

The module will enter into standby mode if:

1. The mains voltage drops below AC_{min} or falls out completely.
2. The standby pin is pulled low.
3. Temperature protection is triggered
4. Over current protection is triggered

In all events the ICEpower250ASP will shut off instantly ($t_{psd} = 200\mu s$ typical) by disabling the switching power stage. Following a power down event the ICEpower250ASP will follow the standard power-up sequence.

Thermal Design

Thermal design is generally a great challenge in power amplifier systems. Linear amplifier designs operating in class A or AB are normally very inefficient and therefore equipped with extensive heat sinking to keep the transistor junction temperature low. The ICEpower250ASP is based on highly efficient ICEpower switching technology providing high overall efficiency characteristics at all levels of operation.

Part of the “component” philosophy of the ASP-series is to provide a self-cooled component thus eliminating the need for special attention to thermal design.

The ICEpower250ASP is designed for music reproduction, which means that the output power of the amplifier will never be continuous. If the average power exceeds 90W @ 4 Ω (typical) for a long time at 25°C ambient temperature, the module will reach its maximum allowable temperature and the temperature protection will be activated. At 50°C ambient temperature more than 35W @ 4 Ω (typical) average power will activate the temperature protection.

For extreme loading requirements with a high continuous average loading or ambient temperatures above 40°C, we recommend the use of an external heat sink, which will improve the FTC power rating.

Further information is located in the ICEpower ASP Designer’s Manual.

Fuses

The ICEpower250ASP has been safety approved using the following fuses

115V Mains: T3.15AH 125V

Wickmann/Littlefuse series 181 or series 215

230V Mains: T2.5AH 250V

Wickmann/Littlefuse series 181 or series 215

T: time-lag H: high-breaking

5*20mm, according to IEC60127-2/5 and UL248.14

High-breaking capability (1500A) fuses are used for safety reasons and to allow powering up more than 30000 times. Fuses from different vendors are not guaranteed to be alike and in any case the module is only safety approved with the above-mentioned fuses.

The ICEpower250ASP is fitted with the fuse suitable for 230V use (and with the voltage selector set to 230V) on delivery as this is the safest setup for protecting the module for global use. To use the ICEpower250ASP in 100V/115V areas, please set the voltage selection jumper to 115V and change the fuse to the type listed above for 115V.

Physical Dimensions

All dimensions are in mm.

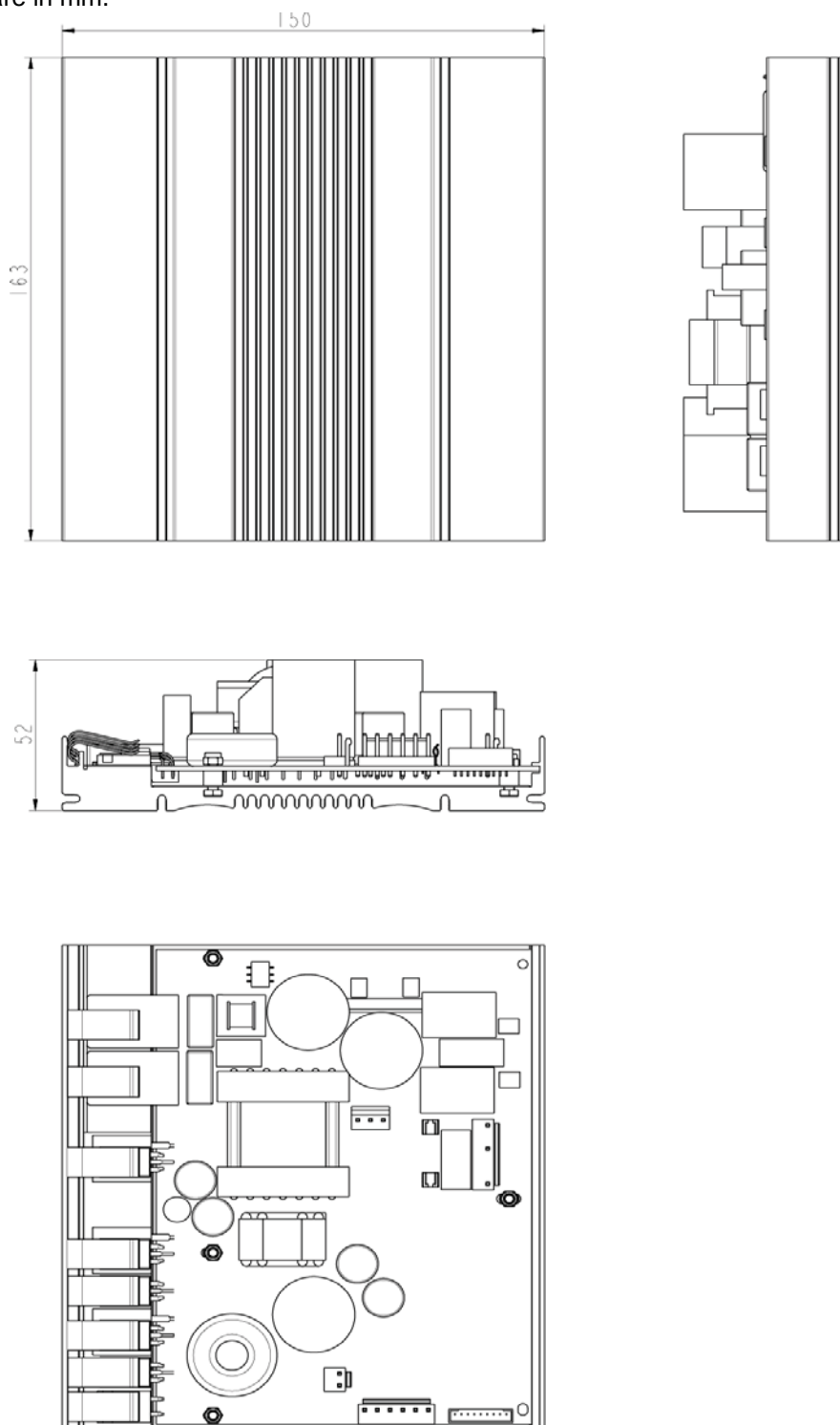

Figure 23: Physical dimensions in mm.

Important! A minimum clearance of 12 mm. above the module is required for safety and ventilation reasons.

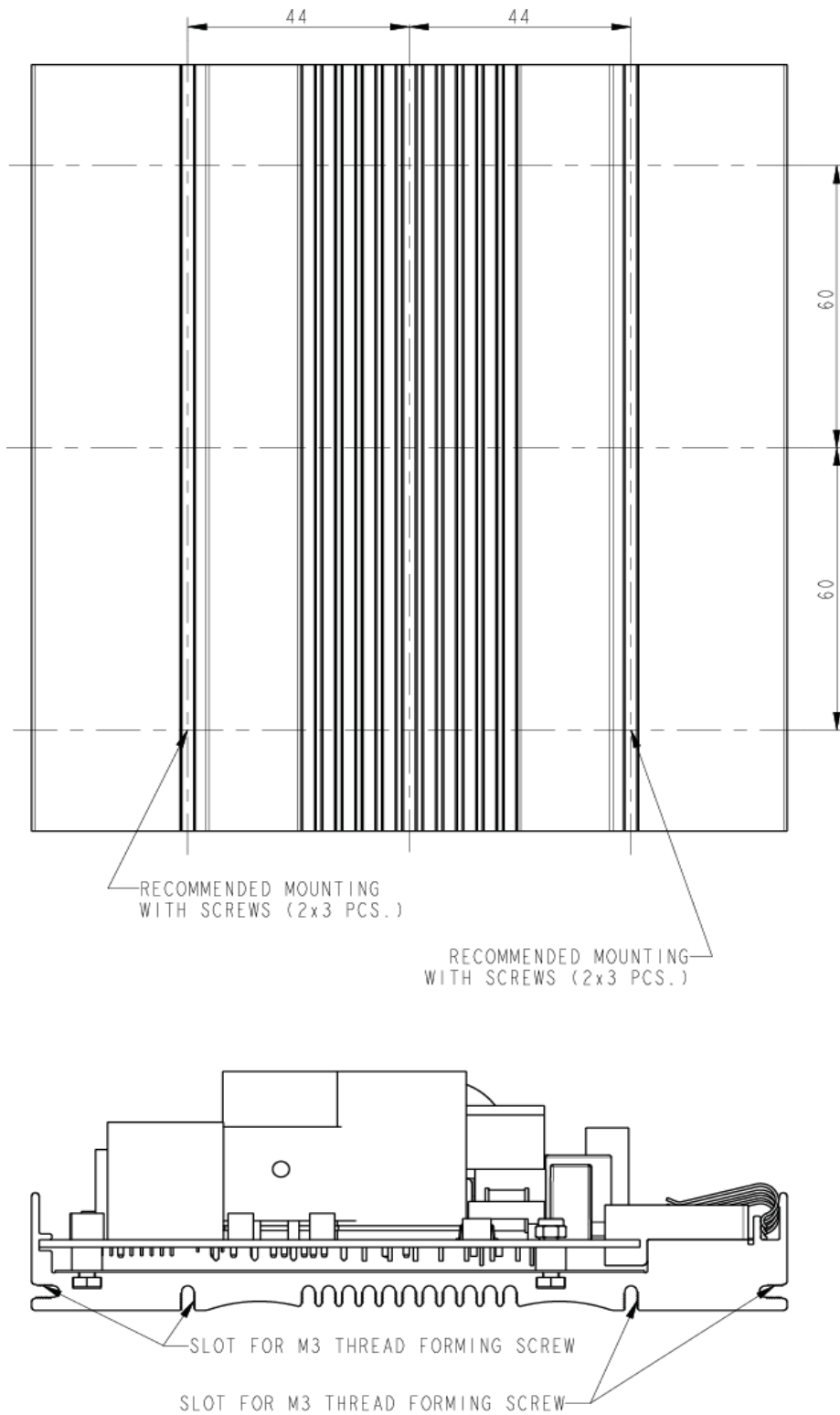

Figure 24: Physical dimensions for mounting slots in mm

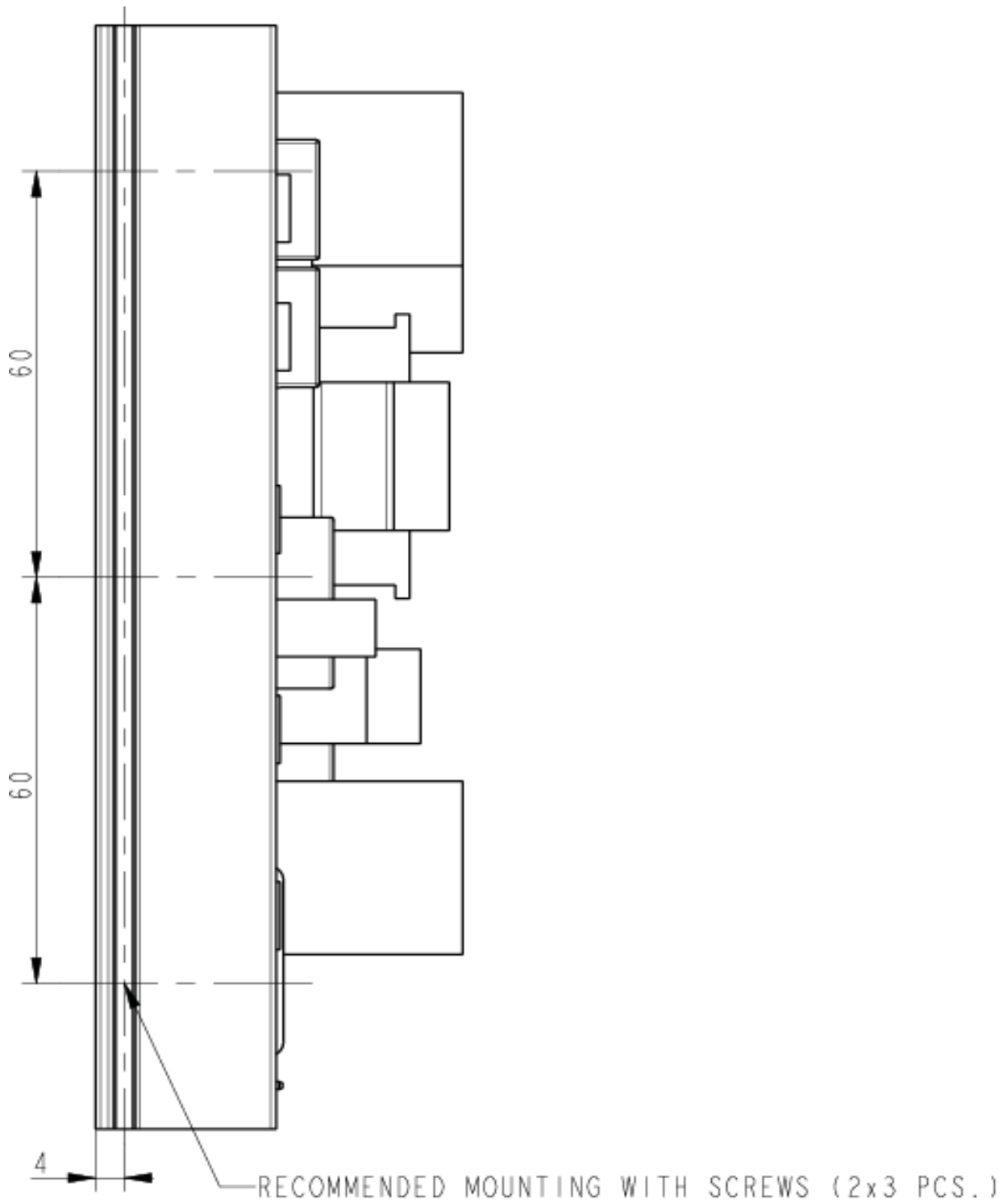

Figure 25: Physical dimensions for mounting slots in mm.

Safety Standards

The ICEpower250ASP has been pre-approved for safety by CSA to ease the design-in procedure and complies with the following standards:

Europe:	IEC 60065 7th ed. + AM1 + AM2 IEC 60065 8th ed EN 60065:2002 + A1:2006 + A11:2008 + A2:2010 + A12:2011 EN 60065:2014
US:	UL 60065, 7th Edition, 2013-07-24 CAN/CSA-C22.2 No. 60065-03, 1st Edition + A1:2006 + A2:2012

Safety class

Class 1 (with earth)

EMC

- EN 55032: Note 1

Note1: Depends on cable routing on the mains/amplifier outputs and load characteristics. Connecting safety ground to the mains side/ Additional filtering may be needed.

ESD Warning

ICEpower products are manufactured according to the following ESD precautions:

- IEC 61340-5-1: Protection of electronic devices from electrostatic phenomena. General Requirements.
- IEC 61340-5-2: Protection of electronic devices from electrostatic phenomena. User Guide.
- ANSI/ESD-S20.20-1999: Protection of Electrical and Electronic Parts, Assemblies and Equipment.

Further handling of the products should comply with the same standards.

The general guarantee policy of ICEpower a/s does not cover ESD damaged products due to improper handling.

Packaging and Storing

The ICEpower250ASP is delivered on pallets of 80 units. Each pallet has 5 x 2 cartons, each with 8 units.

Dimensions and Weight

	Dimensions (W x L x H) [cm]	Weight [kgs]
Carton	57 x 35 x 18	9.8
Pallet	80 x 60 x 105	105

ESD safe cardboard is used for wrapping.

Storage Humidity

Do not expose the pallets to rain or humidity levels higher than 85%.

Storage Temperature

The pallets are to be stored at temperatures from 0°C to 70°C.

Stacking

Pallets may not be stacked on top of each other.

Contact

For additional information about the ICEpower® technology from ICEpower a/s, visit our website or contact us.

ICEpower a/s
Vandtårnsvej 62A, 3rd floor B
DK-2860 Søborg
Denmark

www.icepower.dk
info@icepower.dk

Legal Notes

ICEpower a/s believes that the information in this datasheet is accurate and reliable. However it is provided "as is" without any warranties of any kind. ICEpower a/s and its suppliers, to the fullest extent permitted by law, disclaim all warranties, including the warranty of merchantability, warranty of non-infringement of third-party rights, and the warranty of fitness for a particular purpose. ICEpower a/s and its suppliers make no warranties about the accuracy, reliability, completeness, or timeliness of the material, services, software, text, graphics and links. In no event will ICEpower a/s be liable to any party for any damages whether direct, indirect, special, consequential or other for any use or inability to use of this datasheet, including, without limitation, any damages for lost profits, business interruption, loss of programs or other data on your information handling system or otherwise, even if we are expressly advised of the possibility of such damages.

Information in this datasheet may contain technical inaccuracies or typographical errors. The information in the datasheet may be changed at any time without prior notice or obligation.

ICEpower® is a trademark of ICEpower a/s.

ICEpower a/s products are not authorized for use as critical components in life support devices or life support systems without the express written approval of the president and general counsel of ICEpower a/s. As used herein:

- Life support devices or systems are devices or systems which, (a) are intended for surgical implant into the body, or (b) support or sustain life, and whose failure to perform when properly used in accordance with instructions for use provided in the labelling, can be reasonably expected to result in a significant injury to the user.
- A critical component is any component of a life support device or system whose failure to perform can be reasonably expected to cause the failure of the life support device or system, or to affect its safety or effectiveness.

ICEpower a/s ©2016