

ICEpower a/s, Vandtårnsvej 62A 3B, DK-2860 Søborg
Phone [45] 31 71 00 01, CVR-no. 25053591
info@icepower.dk, www.icepower.dk

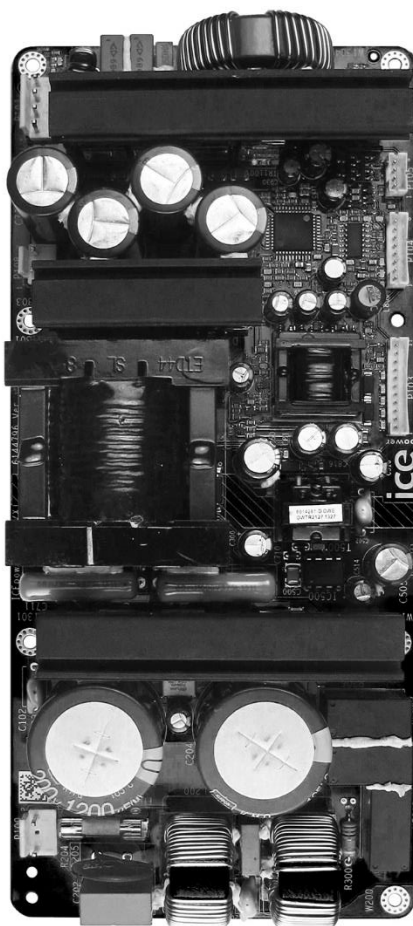

700AS1

ICEpower700AS1

Single Channel 700W ICEpower Amplifiers with Integrated Power Supply

Version 1.9

Contents

CONTENTS..... 2

GENERAL DESCRIPTION 4

RELEASE NOTES..... 5

BLOCK DIAGRAM 6

 700AS1 6

CONNECTORS..... 7

 700AS1 Connectors Overview 7

 P100: Mains Connector 7

 P103: Auxiliary Supply Connector 8

 P104: Signal Connector Specifications 8

 P105: Trigger / LED Connector Specifications 8

 P106: Signal Sense Connector Specifications 8

 P107: Speaker Connector 9

 P108: Hanger Vd Connector 9

ABSOLUTE MAXIMUM RATINGS 9

 Mains Input Section 9

 Auxiliary Supplies 9

 Input Section 10

 Output Section 10

ENVIRONMENTAL SPECIFICATIONS 10

POWER SPECIFICATIONS..... 11

AUDIO SPECIFICATIONS 12

ELECTRICAL SPECIFICATIONS 13

 General..... 13

 ±15 V Auxiliary Converter 13

 5.1 V Standby Converter 13

 Trigger/LED Section..... 14

MECHANICAL SPECIFICATIONS 15

TYPICAL PERFORMANCE CHARACTERISTICS 16

 Frequency Response 16

 Harmonic Distortion and Noise..... 17

OUTPUT IMPEDANCE..... 20

DAMPING FACTOR 20

POWER EFFICIENCY..... 21

DISSIPATED POWER 21

INPUT/OUTPUT SCHEMATICS AND FEATURES 22

 Input Stage 22

 Output Stage 22

 Over Current Monitor Pin 22

 Thermal Shutdown Pin..... 23

 Temperature Monitor Pin 23

 Amplifier Enable..... 23

 23

- Auxiliary Power Supply..... 23
- Hanger Vd..... 24
- Trigger and Signal Sense 24
- LED Programming..... 24
- OPERATIONAL TIMING DIAGRAMS..... 26
 - Timing with Trigger input 26
 - Timing with Signal Sense 28
- PROTECTION FEATURES..... 29
 - Power Supply Protection..... 29
 - Amplifier Protection..... 29
 - Standby Converter 29
- INTEGRATION GUIDELINE 31
 - Typical Setup – Wiring diagram 31
 - Grounding Scheme 34
 - EMC management..... 35
 - Thermal Design 37
- MECHANICAL MOUNTING 38
 - Mounting on bottom side spacers 38
 - Mounting by top side Heat Sinks 39
- STANDARDS 41
 - Safety 41
 - EMC 41
- ESD WARNING 42
- PACKAGING AND STORING 42
 - Storage Humidity and Temperature 42
 - Stacking 42
- CONTACT 43
- LEGAL NOTES 43

General Description

ICEpower700AS1 is fully integrated, compact and efficient audio power conversion solution which supports universal mains operation and complies to ErP and Energy Star® requirements.

ICEpower700AS1 is designed for highly competitive consumer and professional audio products, e.g. subwoofers, A/V amplifiers, active speakers and multi way systems. ICEpower700AS1 is EMC and safety pre-approved including amplifier hanger options. ICEpower700AS1 enables fast design-in and minimum time to market.

Features

Suitable for CE and FCC approved designs; EMC and safety pre-approved

Fully integrated amplifier and power supply with mains-converter and auxiliary-converter

ICEpower amplifier hanger support for easy addition of amplifier channels (with 300A1)

Designed for flexible mounting and, if needed, easy mechanical interface to external heat sinking for even higher continuous power capability

Patented HCOM modulation and control techniques for excellent audio performance

Sound optimized soft clipping

Thermal and over-current protection

Standby converter with low standby power consumption

Universal mains

Wake-on-signal, logic triggers and programmable LED drivers

Key Specifications

- 700 W @ 1 % THD+N, 20 Hz – 20 kHz, 4 Ω
- 117 dBA dynamic range
- THD+N = 0.005 % @ 1 W (4 Ω, 1 kHz)
- THD+N = 0.0008 % @ 50 W (4 Ω, 100 Hz)
- CCIF IM distortion = 0.0003 %, 10 W, 4 Ω, 18.5 kHz / 1 kHz
- Maximum output voltage / current 76 Vp / 30 Ap
- Low output impedance of 6 mΩ
- 84 % total efficiency @ 700 W, 4 Ω
- ±15V / 0.5A regulated AUX power supply
- Dimensions (w × d × h) = 220 mm × 100 mm × 46 mm
8.66 in × 3.94 in × 1.81 in
- Weight 790 g
28 oz

Key Specifications

- Universal mains operation (100-240 V, 50-60 Hz)
- Standby converter with 5.1 V, 1 A output
- Standby power consumption 170 mW @ 230 V
- Standby payload 200 mW
- ErP (1275/2008/EC) compliant
- Energy Star®v3.0 compliant

Release Notes

Data Sheet Version	Date	Revised by	Description
1.0	2014-09-08	HKS/SMK	Release version
1.1	2014-10-06	HKS	Connectors overview p. 8 updated
1.2	2016-01-06	MFM/SOL	Module name 700ASC updated to 700AS1 – product is identical
1.3	2017-06-01	TOC/DIT	Address updated Legal Notes updated
1.4	2017-09-26	DIT/LBH	Note added to table for Auxiliary Supplies Minor design changes
1.5	2018-06-19	LBH/DIT	Output voltage / current spec. added Safety and EMC standards updated
1.6	2018-11-06	LBH/DIT	Absolute Maximum Ratings updated
1.7	2019-11-11	LBH	Mains power consumption added
1.8	2020-05-15	LBH/NKK	Removal of 700ASX from datasheet
1.9	2023-04-11	LKA	List of safety-standards updated

Block Diagram

700AS1

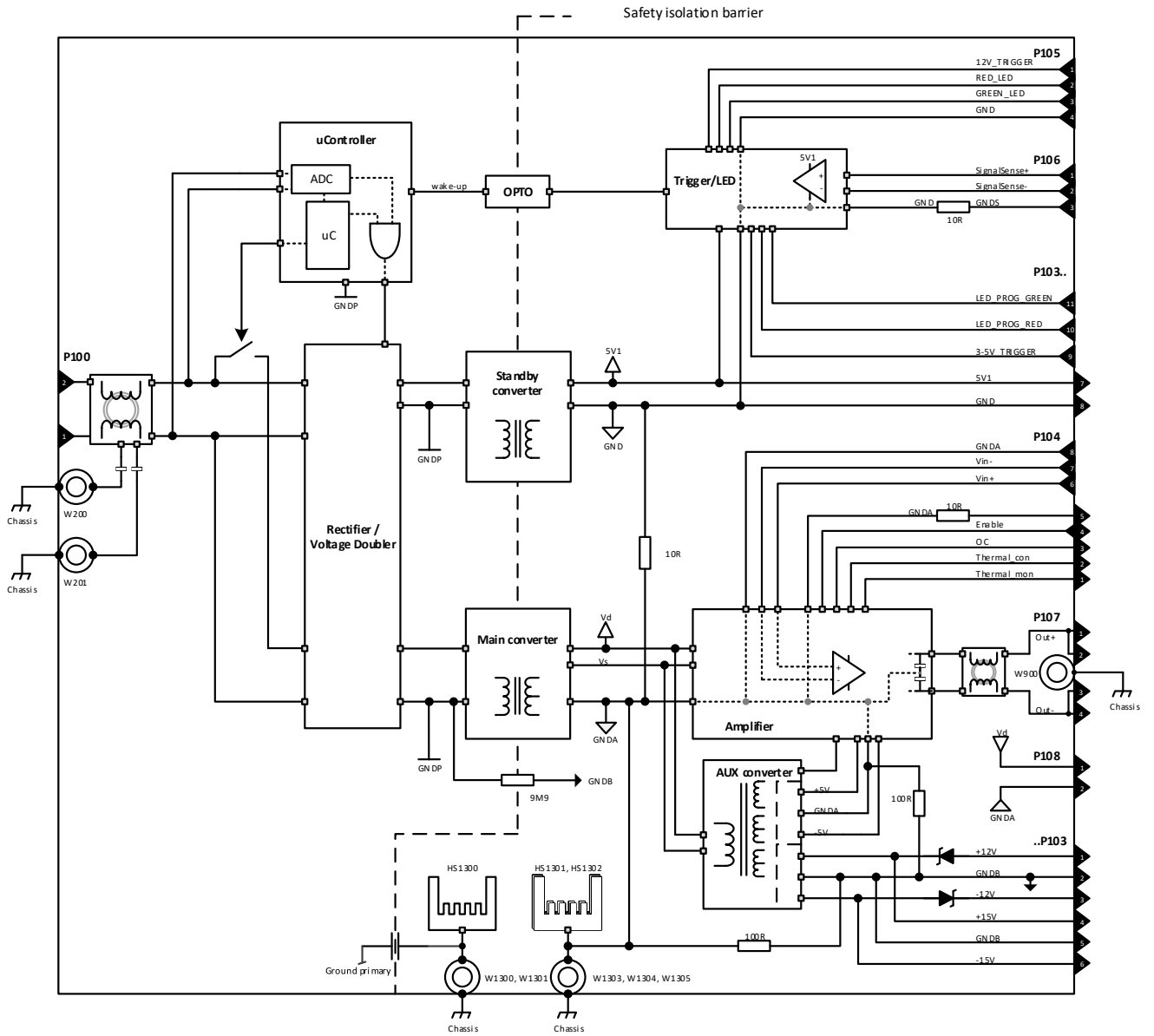

Figure 1: ICEpower700AS1 block diagram

Connectors

The ICEpower700AS1 module come with industry standard connectors selected for long-term reliability.

700AS1 Connectors Overview

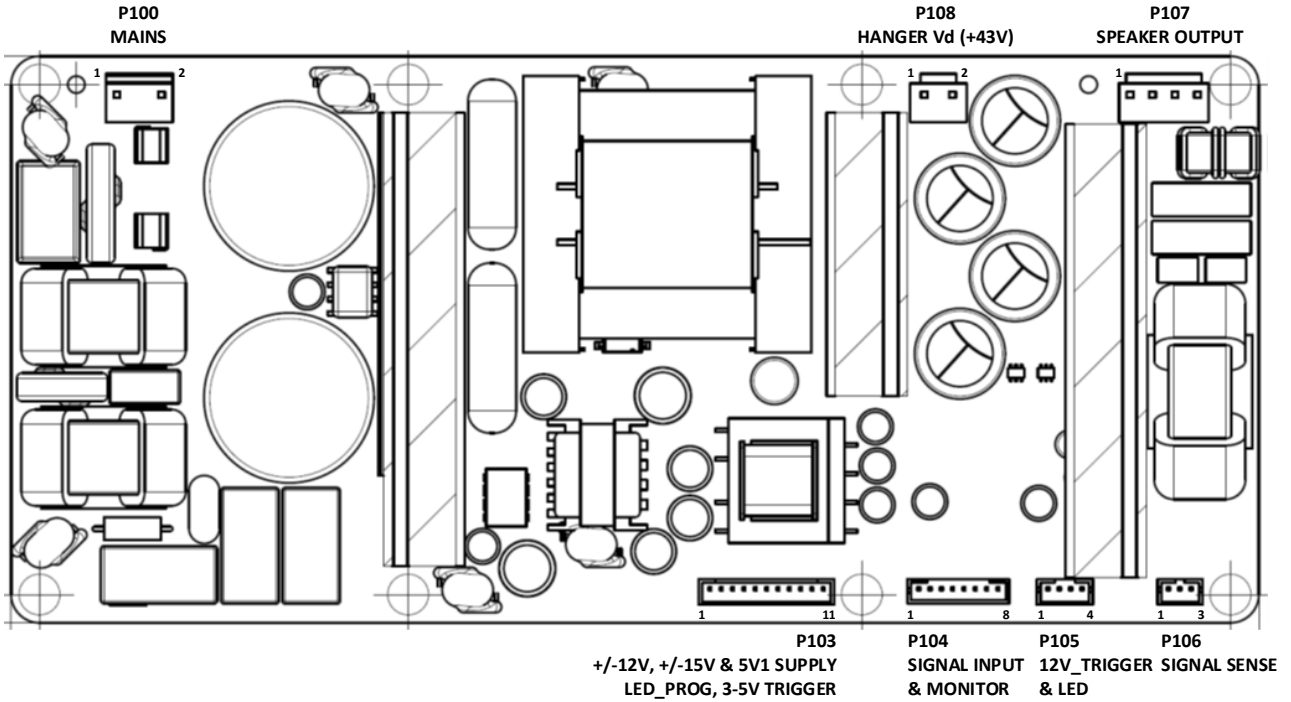

Figure 2: ICEpower700AS1 connectors overview

P100: Mains Connector

Type: JST B2P3-VH(LF)(SN)

PIN	Function	Description	Type
1	Neutral	Neutral AC	Input
2	Live	Live AC	Input

Table 1: Mains connector

P103: Auxiliary Supply Connector

Type: JST B11B-PH-K-S(LF)(SN)			
PIN	Function	Description	Type
1	+12V	For one ICEpower300A1 hanger only! Positive supply	Output
2	GNDB	For one ICEpower300A1 hanger only! Ground terminal	GND
3	-12V	For one ICEpower300A1 hanger only! Negative supply	Output
4	+15V	Positive regulated auxiliary supply	Output
5	GNDB	Ground terminal for the auxiliary supply section.	GND
6	-15V	Negative regulated auxiliary supply	Output
7	5V1	Regulated standby converter supply	Output
8	GND	Ground terminal for the standby converter and control section	GND
9	3-5V_trigger	Logic trigger for controlling On/Standby mode	Input
10	LED_PROG_RED	Programming pin for red LED driver	Input
11	LED_PROG_GREEN	Programming pin for green LED driver	Input

Table 2: Auxiliary Supply connector

P104: Signal Connector Specifications

Type: JST B8B-PH-K-S(LF)(SN)			
PIN	Function	Description	Type
1	Thermal monitor	Amplifier temperature monitoring	Output
2	Thermal shutdown	Amplifier thermal shutdown monitor	Output
3	OC	Amplifier over current monitor	Output
4	Amplifier Enable	Amplifier enable	Input / Output
5	GNDD	Ground terminal for the Amplifier Enable and monitor section.	GND
6	Signal+	Positive audio signal input	Input
7	Signal-	Negative audio signal input	Input
8	GNDA	Ground terminal for the signal section.	GND

Table 3: Signal connector specifications

P105: Trigger / LED Connector Specifications

Type: JST B4B-PH-K-S(LF)(SN)			
PIN	Function	Description	Type
1	12V_trigger	Logic trigger for controlling On/Standby mode	Input
2	RED_LED	Red LED driver output	Output
3	GREEN_LED	Green LED driver output	Output
4	GND	Ground terminal for the standby converter and control section	GND

Table 4: Trigger/LED connector

P106: Signal Sense Connector Specifications

Type: JST B3B-PH-K-S(LF)(SN)			
PIN	Function	Description	Type
1	Signal Sense+	Positive audio input for wake-on-signal	Input
2	Signal Sense-	Negative audio input for wake-on-signal	Input
3	Signal Sense, GND	Ground for the Signal Sense section	GND

Table 5: Signal Sense connector

P107: Speaker Connector

Type: JST B4P-VH(LF)(SN)			
PIN	Function	Description	Type
1	Vo+	Amplifier positive output	Output
2	Vo+	Amplifier positive output	Output
3	Vo-	Amplifier negative output	Output
4	Vo-	Amplifier negative output	Output

Table 6: Speaker connector

P108: Hanger Vd Connector

Type: JST B02P-NV(LF)(SN)			
PIN	Function	Description	Type
1	Vd, +43 V	For ICEpower hanger only! DC positive supply	Output
2	GNDA	For ICEpower hanger only! DC ground	Output

Table 7: Hanger connector

Absolute Maximum Ratings

Absolute maximum ratings indicate limits above which damage may occur.

Mains Input Section

700AS1 with Universal Mains

Connector	Parameter	Value	Units
P100: 1, 2	Maximum mains voltage (safety test)	264 ¹	V _{AC}
P100: 1, 2	Minimum mains voltage (safety test)	85 ¹	V _{AC}
P100: 1, 2	Maximum mains frequency	65	Hz
P100: 1, 2	Minimum mains frequency	45	Hz

Table 8: Absolute maximum ratings, mains input section

¹The maximum operating/usage mains voltage is 240Vac and the minimum operating/usage mains voltage is 100Vac.

Auxiliary Supplies

Connector: Pin	Parameter	Value	Unit
P103: 4, 5, 6	Maximum current draw from +/-15 V		
	No hanger connected	500	mA
	One ICEpower300A1 hanger connected	415	
	Two ICEpower300A1 hangers connected	330	
P103: 4, 5	Maximum external capacitance +/-15 V	470	uF
P103: 6, 5			
P103: 7, 8	Maximum current draw from 5V1 in Standby mode ²	50	mA
P103: 7, 8	Maximum current draw from 5V1 in Operational mode	1.0	A
P103: 7, 8	Maximum external capacitance 5V1	1000	uF

Table 9: Absolute maximum ratings, auxiliary supply

²The 5V1 can deliver 1A in standby mode (0,5A during power up), but to ensure standby power consumption below 0.5W, the maximum current draw from 5V1 is set to 50mA.

Input Section

Connector: Pin	Parameter	Value	Unit
P104: 6, 8 P104: 7, 8	Maximum voltage range on audio input pin	±12	V _p
P103: 9, 8	Maximum 3 V - 5 V trigger voltage	37	V
P103: 10, 11, 8	Maximum LED programming voltage	5.3	V
P105: 1, 4	Maximum 12 V trigger voltage	45	V
P106: 1, 3	Maximum current on Signal Sense (clamping at ±2.5 V, otherwise Z _{in} > 1 MΩ)	10	mA
P106: 2, 3	Maximum current on Signal Sense (clamping at ±2.5 V, otherwise Z _{in} = 47 kΩ)	10	mA

Table 10: Absolute maximum ratings, input section

Output Section

Connector: Pin	Parameter	Value	Units
P107: (1+2), (3+4)	Minimum amplifier load resistance	2.5	Ω
P107: (1+2), (3+4)	Maximum current draw from amplifier output	30	A
P107: (1+2), (3+4)	Maximum amplifier pure capacitive load	220	nF

Table 11: Absolute maximum ratings, output section

Environmental Specifications

Parameter	Conditions	Min	Typ	Max	Units
Ambient temperature, operating	Natural convection cooling	0		50	°C
Ambient temperature, storage		-40		70	°C
Ambient temperature, shelf		0		60	°C
Relative humidity	Non-condensing			85	%
Altitude, operating				2000	m
Vibration level 700AS1	Measured on relays, all directions			4	g

Table 12: Environment specifications

Power Specifications

Unless otherwise specified. $T_a = 25\text{ °C}$, $f = 1\text{ kHz}$, $R_L = 4\text{ }\Omega$, 230 V mains

Parameter	Conditions	Min	Typ	Max	Units
Nominal DC voltage	Mains input within range		+43.5		V
Positive analog/digital supply	Mains input within range	+4.9	+5.1	+5.3	V
Positive analog supply	Mains input within range	+14.3	+15,3	+16.0	V
Negative analog supply	Mains input within range	-16.0	-15,3	-14.3	V
Time of maximum rated output power	700 W out. No preheating.		>300		s
Continuous output power without thermal shutdown. (4 Ω)	Thermal stab. @ $T_a = 25\text{ °C}$.		270		W
Continuous output power without thermal shutdown. (8 Ω)	Thermal stab. @ $T_a = 25\text{ °C}$.		270		W
Quiescent power consumption (amplifier disabled)	Amplifier Enable pin low		7		W
Quiescent power consumption (amplifier enabled)	$P_o = 0\text{ W}$		18		W
Standby power consumption	$I_{LED} = 0\text{ A}$, $I_{SV1} = 0\text{ A}$, 230 VAC		170		mW
Mains power consumption	$P_o = 125\text{W } 4\Omega$ (AUX not incl) P_o from 700AS1+300A1 Combined, 230 V, 50 Hz 300A1 supplied by 700AS1 AUX supply $I_{SV1} = 1.0\text{A}$, $I_{\pm 15\text{V}} = 0.415\text{A}$		195		W
Total power efficiency	$P_o = 100\text{ W } 4\text{ }\Omega$ $P_o = 700\text{ W } 4\text{ }\Omega$		76 84		%

Table 13: Power specifications

Audio Specifications

Unless otherwise specified, $f = 1 \text{ kHz}$, $P_o = 1 \text{ W}$, $T_a = 25 \text{ }^\circ\text{C}$.

Measurements were done using an Audio Precision AES17 20 kHz 7th order measurement filter unless otherwise specified.

Parameter	Conditions	Min	Typ	Max	Units
Output power @ 1 % THD+N $f = 1 \text{ kHz}$	$R_L = 4 \Omega$ 230 V _{ac} / 50 Hz, 115 V _{ac} / 60 Hz, 100 V _{ac} / 50 Hz, 85 V _{ac} / 50 Hz		720 720 700 560		
Output power @ 1 % THD+N 20 Hz < f < 20 kHz	$R_L = 4 \Omega$ 230 V _{ac} / 50 Hz, 115 V _{ac} / 60 Hz, 100 V _{ac} / 50 Hz, 85 V _{ac} / 50 Hz		710 650 560 490		W
Vo-max	Maximum output voltage		76		V _p
Io-max	Maximum output current		30		A _p
THD+N in 4 Ω (AES17 measurement filter)	$f = 100 \text{ Hz}$, $P_o = 1 \text{ W}$		0.006		%
Output referenced idle noise	20 Hz < f < 20 kHz A-weighted Unweighted	50 80	70 100	130 160	μV
Nominal Voltage Gain	$f = 1 \text{ kHz}$		27,4		dB
Frequency response	$f = 20 \text{ Hz} - 20 \text{ kHz}$, $R_L = 4 \Omega - \text{inf. } \Omega$		± 0.5	± 0.7	dB
Upper bandwidth limit (-3 dB)	$R_L = 4 \Omega$		70		kHz
Lower bandwidth limit (-3 dB)	$R_L = \text{All loads}$		1.5		Hz
Abs. output impedance	$f = 1 \text{ kHz}$		7		m Ω
Load impedance range		2,5	4	∞	Ω
Dynamic range	A-weighted at 700 W @ 4 Ω		117		dB
Intermodulation (CCIF)	$f = 18.5 \text{ kHz} / 1 \text{ kHz}$, $P_o = 10 \text{ W}$		0.0003		%
Transient intermodulation (DIM30)	$P_o = 10 \text{ W}$		0.003		%

Table 14: General audio specifications

Electrical Specifications

General

Unless otherwise specified, $T_a = 25\text{ }^\circ\text{C}$.

Parameter	Conditions	Min	Typ	Max	Unit
Nominal mains voltage range		100		240	Vac
Nominal mains frequency range		50		60	Hz
Switching frequency	Idle	460	510	560	kHz
Switching frequency range (amplifier)	Idle to full scale	90		560	kHz
Switching frequency (power supply)		70	140	340	kHz
Switching frequency	Standby mode, $I_{5V1} = 0\text{ A}$		18		kHz
Burst frequency	Standby mode		500		Hz
Switching frequency	Operational mode, $I_{5V1} = 1.0\text{ A}$		100		kHz
Micro controller clock frequency	Operational mode		8		MHz

Table 15: Electrical specifications

$\pm 15\text{ V}$ Auxiliary Converter

Unless otherwise specified, $T_a = 25\text{ }^\circ\text{C}$.

Parameter	Conditions	Min	Typ	Max	Unit
Tolerance of $\pm 15\text{ V}$		± 15.1	± 15.4	± 15.7	V
Load regulation	$0\text{ A} \leq I_{\pm 15\text{ V}} \leq 0.5\text{ A}$		0.6		V
Ripple of $\pm 15\text{ V}$	$I_{\pm 15\text{ V}} = 0.5\text{ A}$		0.25		V _{pp}
Load transition regulation	$I_{\pm 15\text{ V}}$ step up/down 0.2 A, 0.5 A		0.4		V _{pp}
$\pm 15\text{ V}$ overload protection	$0\text{ }^\circ\text{C} \leq T_a \leq 50\text{ }^\circ\text{C}$		0,9		A

Table 16: $\pm 15\text{ V}$ Auxiliary converter electrical specifications

5.1 V Standby Converter

Unless otherwise specified, $T_a = 25\text{ }^\circ\text{C}$.

Parameter	Conditions	Min	Typ	Max	Unit
Tolerance of 5V1		4.9	5.1	5.3	V
Load regulation	$0\text{ A} \leq I_{5V1} \leq 1.0\text{ A}$		50		mV
Mains regulation	$I_{5V1} = 1.0\text{ A}$		10		mV
Temperature variation regulation	$0\text{ }^\circ\text{C} \leq T_a \leq 50\text{ }^\circ\text{C}$, $I_{5V1} = 1.0\text{ A}$		30		mV
Ripple of 5V1	$I_{5V1} = 1.0\text{ A}$		50		mV _{pp}
Load transition regulation	I_{5V1} step up/down 0.2 A, 1.0 A		0.2		Vp
Maximum output current available from 5V1 ensuring standby power consumption < 0.5 W	230 VAC, no LED		40		mA
5V1 overload protection	$0\text{ }^\circ\text{C} \leq T_a \leq 50\text{ }^\circ\text{C}$, steady state	1.05		2.0	A

Table 17: 5.1 V Standby converter electrical specifications

Trigger/LED Section

Unless otherwise specified, $T_a=25\text{ }^\circ\text{C}$.

Parameter	Conditions	Min	Typ	Max	Unit
Signal Sense - Trigger Level	Sine wave 1 kHz		1.5		mV
3-5V trigger – Trigger Level			1.3		V
3-5V trigger – Off Level			1.2		V
12V trigger – Trigger Level			2.7		V
12V trigger – Off Level			2.6		V
Minimum green LED current	LED_PROG_GREEN open		270		uA
Minimum red LED current	LED_PROG_RED open		270		uA
Maximum green LED current	LED_PROG_GREEN shorted to 5V1		6.3		mA
Maximum red LED current	LED_PROG_RED shorted to 5V1		3.8		mA
Available output voltage at maximum red LED current	LED_PROG_RED shorted to 5V1	3.9	4.3		V
Available output voltage at maximum green LED current	LED_PROG_GREEN shorted to 5V1	3.9	4.3		V

Table 18: Trigger/LED electrical specifications

Mechanical Specifications

The ICEpower700AS1 is designed for mounting bottom down via spacers and/or via heat sinks and spacers. Find below the outer dimensions in [mm] of the ICEpower700AS1 module. For drill guides, refer to the section Mechanical Mounting pages 38 and 39.

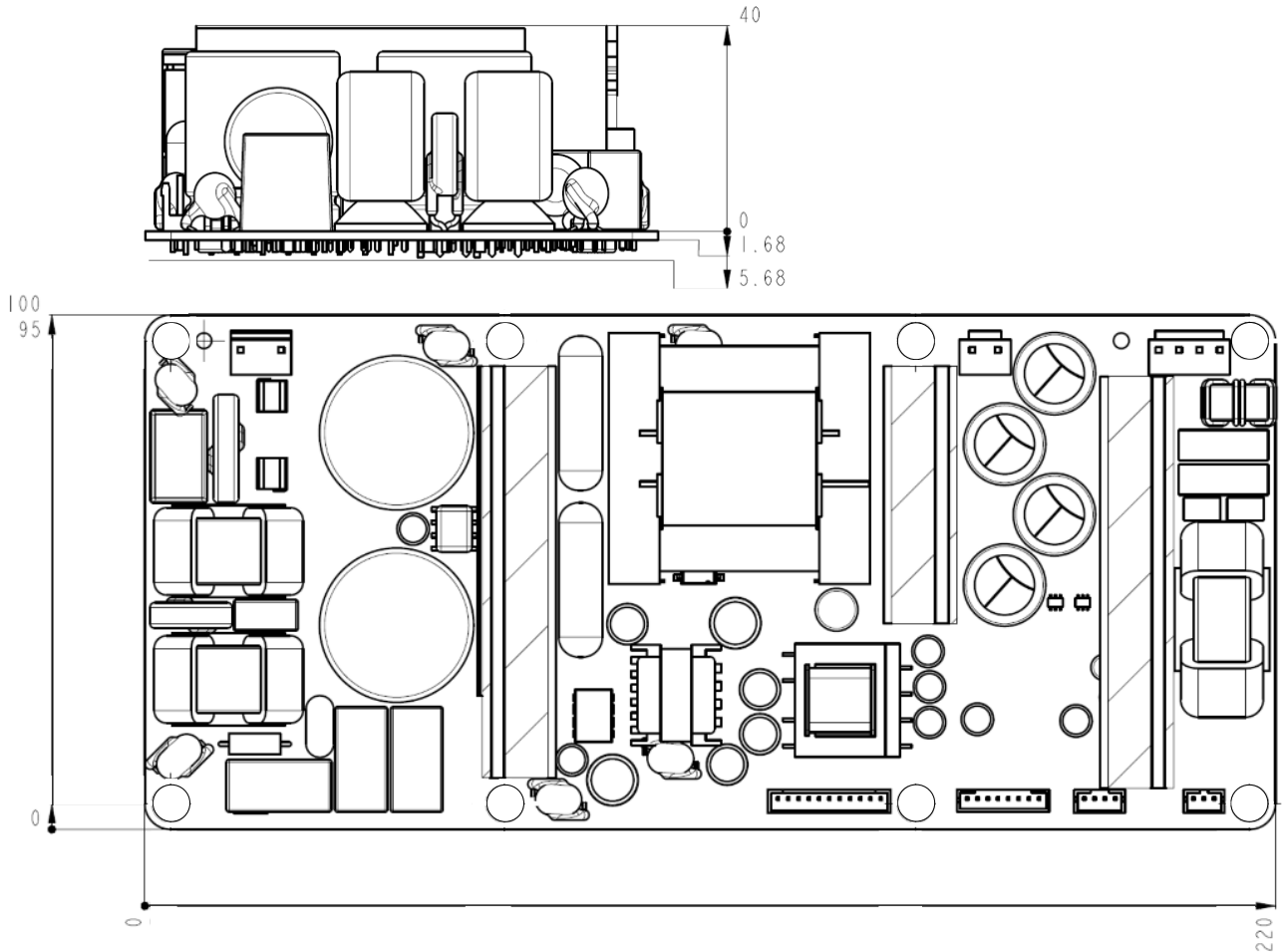

Figure 3: Outer dimensions ICEpower700AS1

A minimum clearance of 12 mm around the module is recommended for safety and ventilation reasons.

Typical Performance Characteristics

Frequency Response

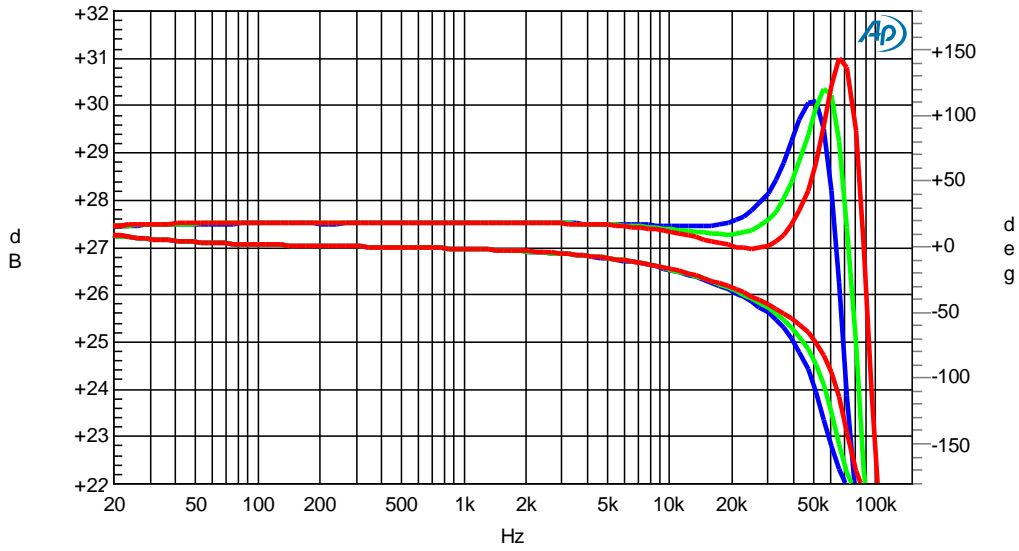

Figure 4: Frequency response in 4 Ω (blue), 8 Ω (green) and open load (red). Top – amplitude. Bottom – phase

Harmonic Distortion and Noise

All measurements are done with an Audio Precision AES17 20 kHz 7th order measurement filter.

THD+N vs. Power

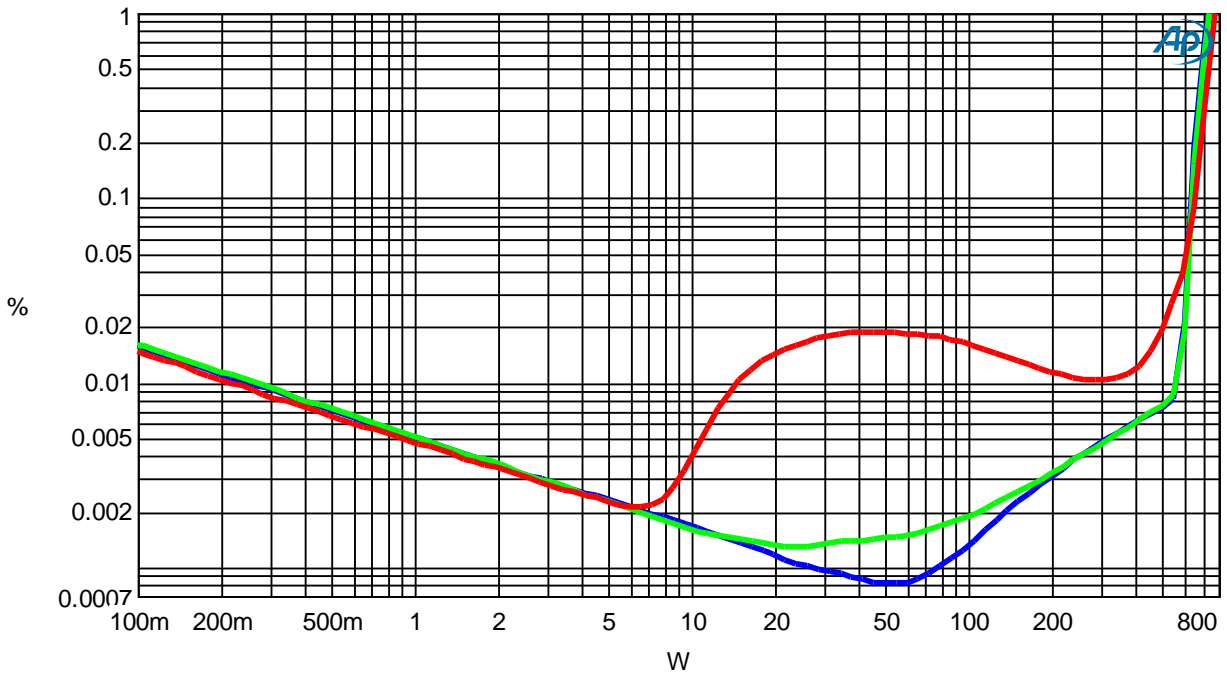

Figure 5: THD+N vs. Po at 100 Hz (blue), 1 kHz (green) and 6.67 kHz (red), 4 Ω, 230 Vac / 50 Hz

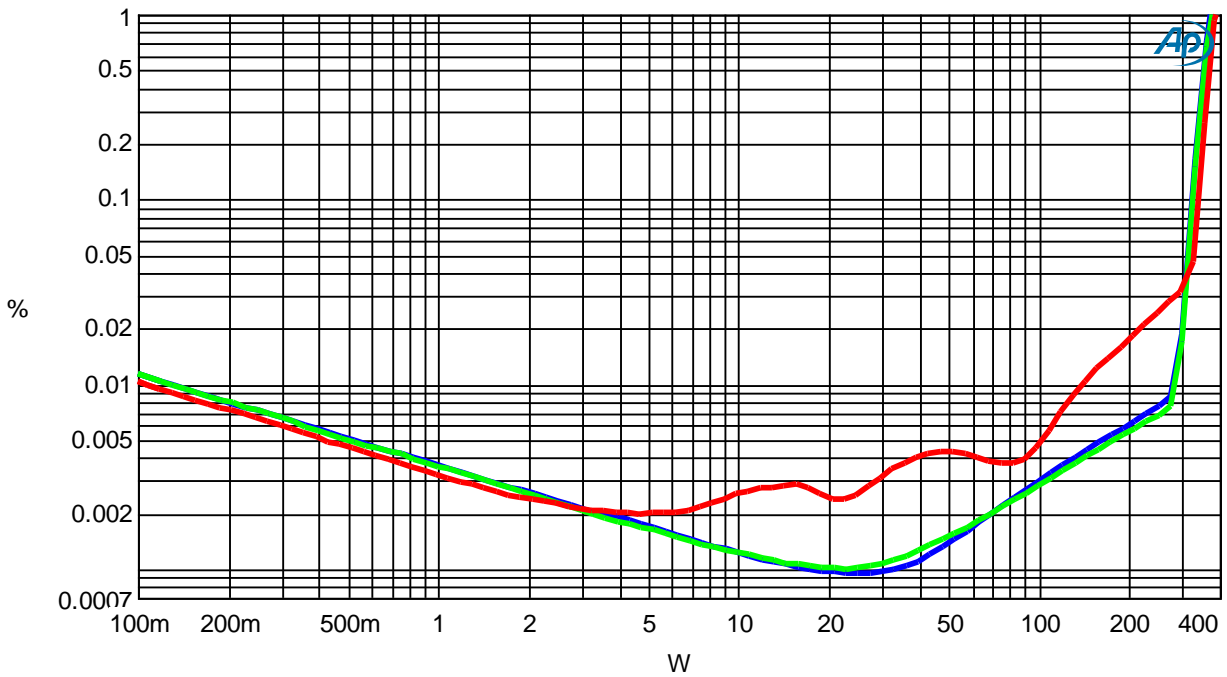

Figure 6: THD+N vs. Po at 100 Hz (blue), 1 kHz (green) and 6.67 kHz (red), 8 Ω, 230 Vac / 50 Hz

Spectral View (FFT)

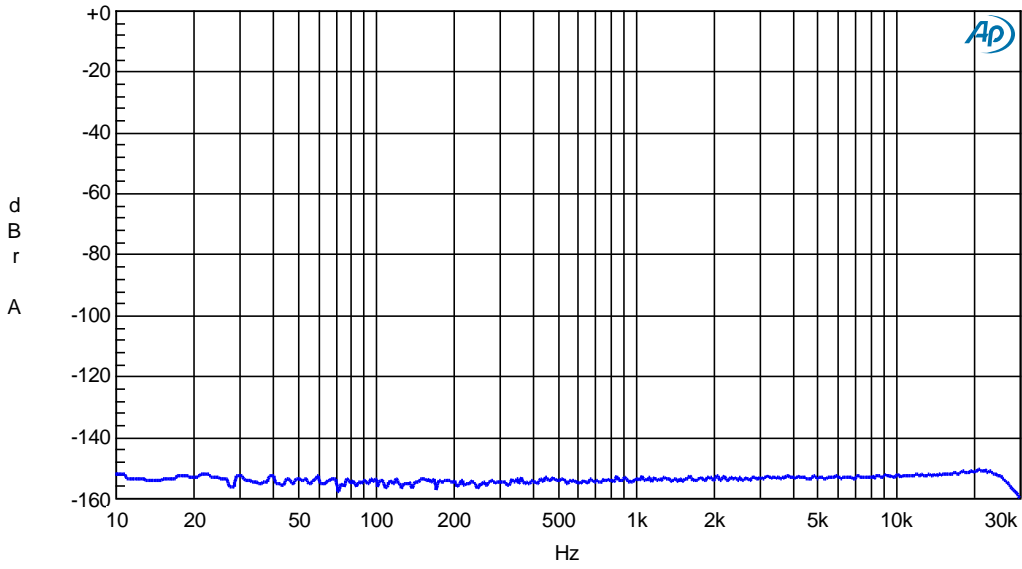

Figure 7: Idle noise (32K FFT). Residual = 70 μ V(A), RL = 4 Ω (Relative to 700 W into 4 Ω)

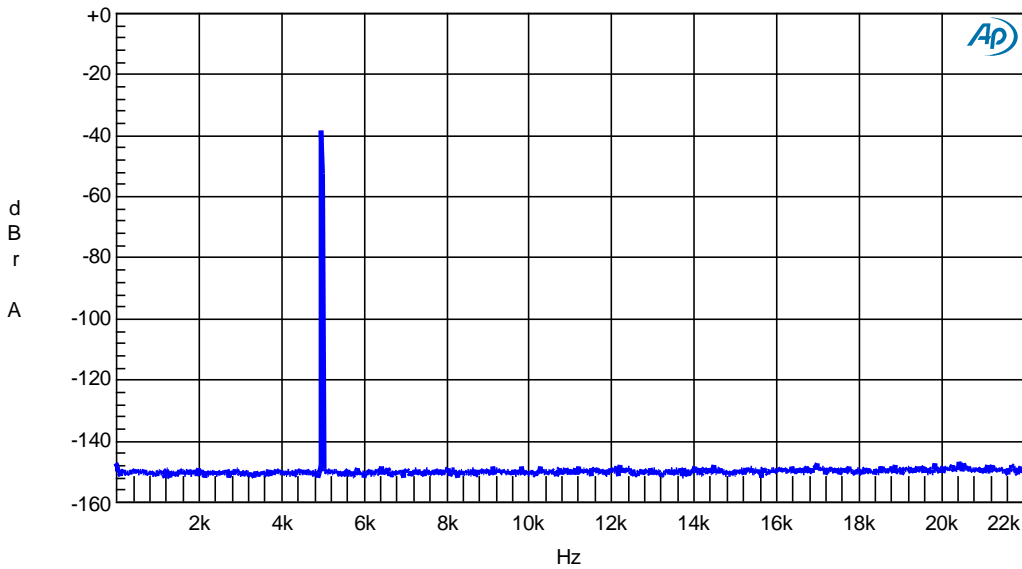

Figure 8: f = 5 kHz. Po = 100 mW, RL = 4 Ω (Relative to 700 W into 4 Ω)

Intermodulation Distortion (CCIF & TIM)

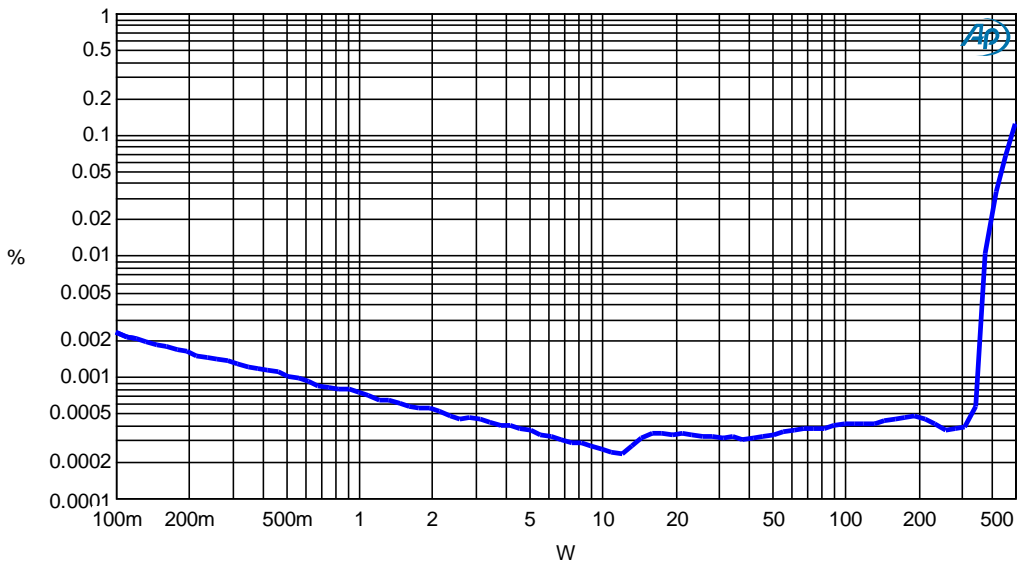

Figure 9: CCIF IMD vs. Output Power, $R_L = 4 \Omega$, $f_1 = 18 \text{ kHz}$, $f_2 = 19 \text{ kHz}$, 1 kHz

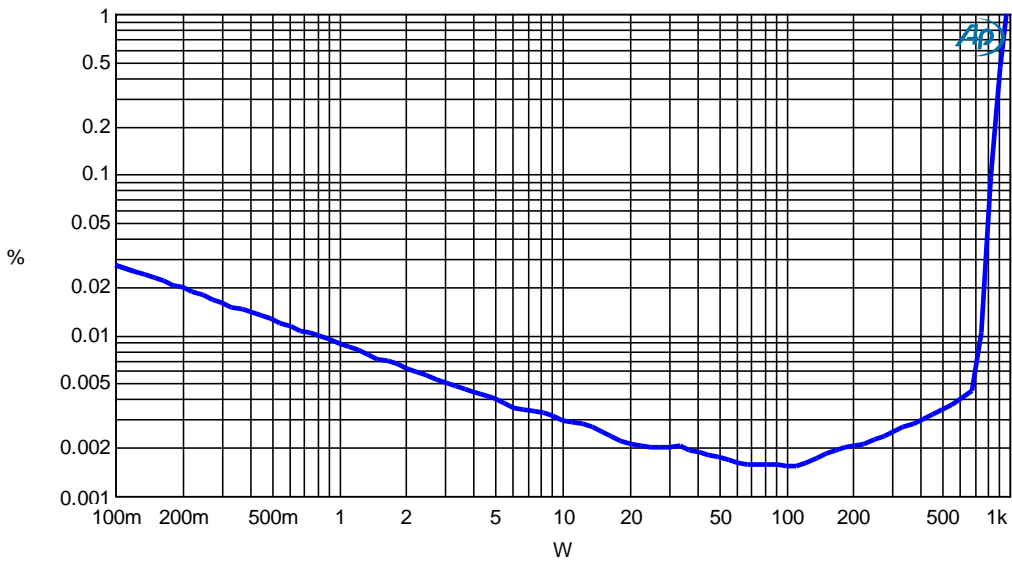

Figure 10: TIM vs. output power. $R_L = 4 \Omega$

Output Impedance

The output impedance is measured using a delta load method where the difference in output amplitude at two different resistive loads is used to calculate the equivalent output impedance of the amplifier. The output impedance is measured directly at the terminals on the PCB.

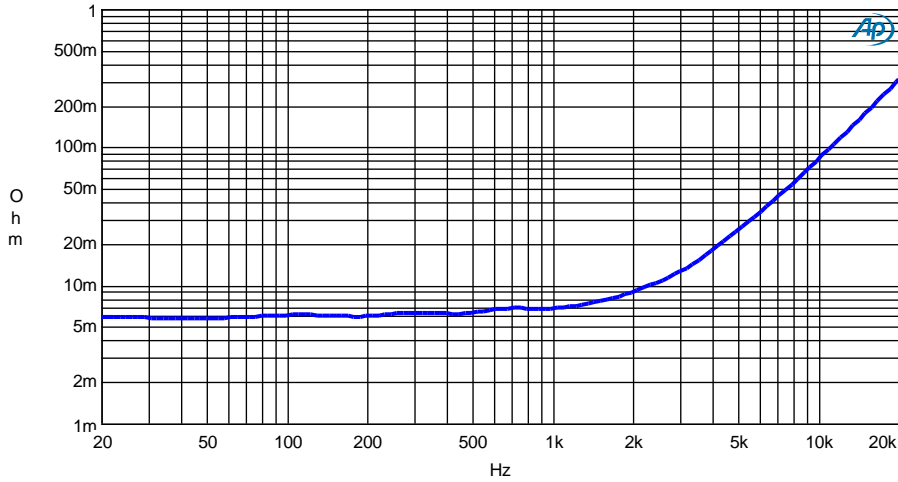

Figure 11: Output impedance at the output terminals

Damping Factor

The damping factor is calculated as the ratio between the output impedance of the amplifier and the load impedance.

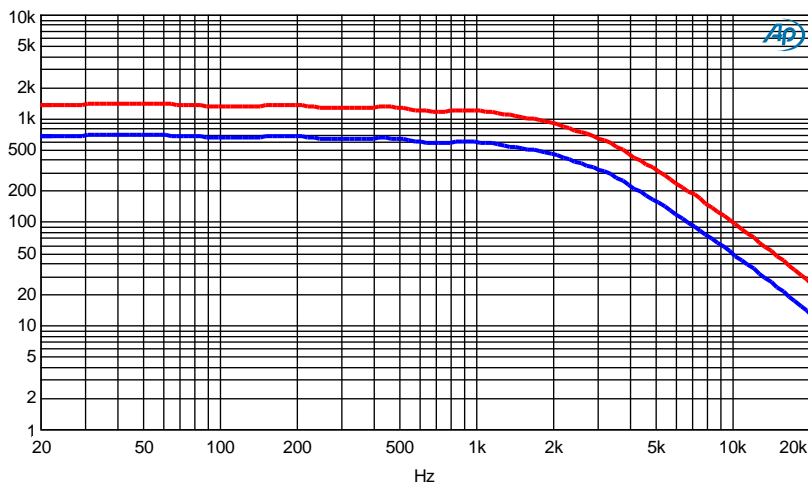

Figure 12: Damping factor vs. frequency 4 Ω (blue) and 8 Ω (red)

With its low output impedance, the ICEpower700AS1 are designed to be unaffected by loudspeaker loading characteristics. However, care should be taken with purely capacitive loads.

Power Efficiency

The total power efficiency from AC mains to amplifier output.

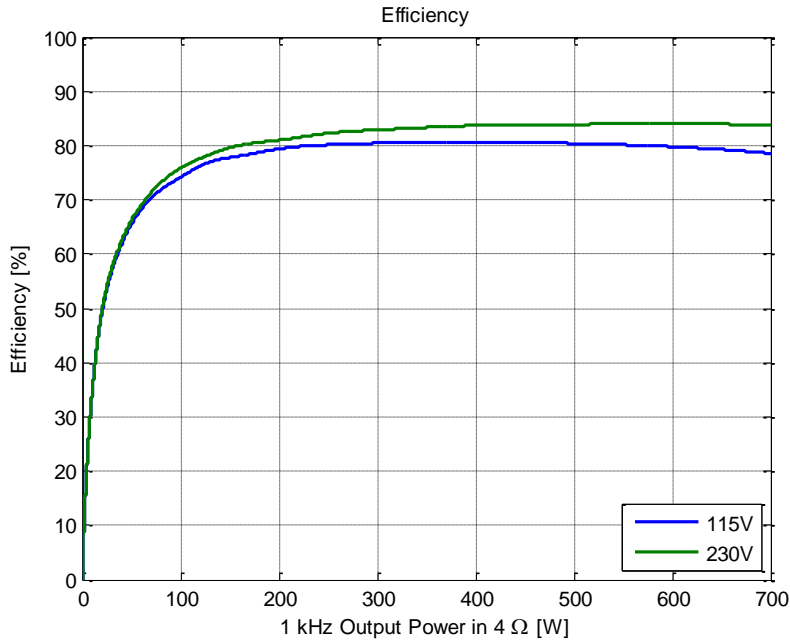

Figure 13: Efficiency vs. output power

Dissipated Power

The total dissipated power within the module from AC mains to amplifier output.

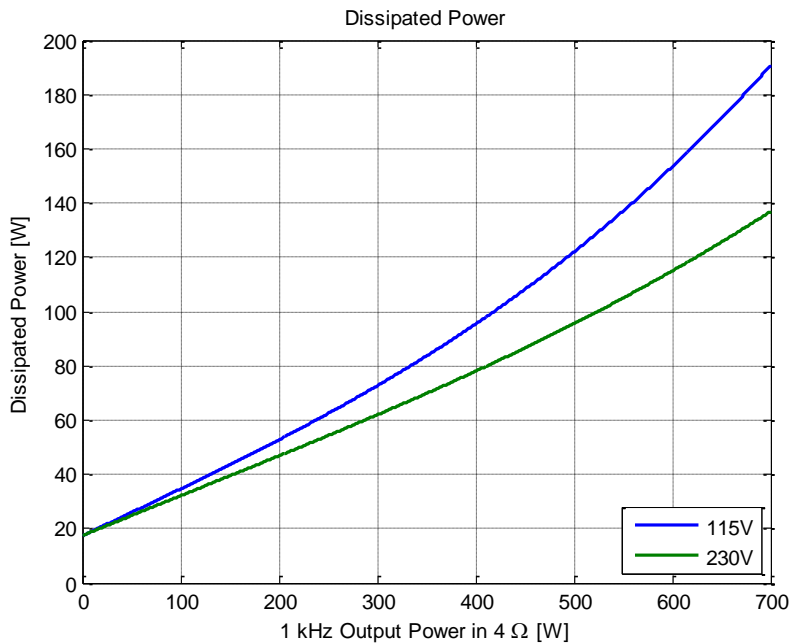

Figure 14: Dissipated power vs. output power

Input/Output Schematics and Features

The ICEpower700AS1 has a number of useful features described below.

Input Stage

The balanced input buffer has an anti-aliasing filter and a DC blocking capacitor. The input impedance of the signal input section is minimum 8 kΩ over the audio bandwidth, which is an acceptable loading condition for pre-amps, active crossover outputs etc.

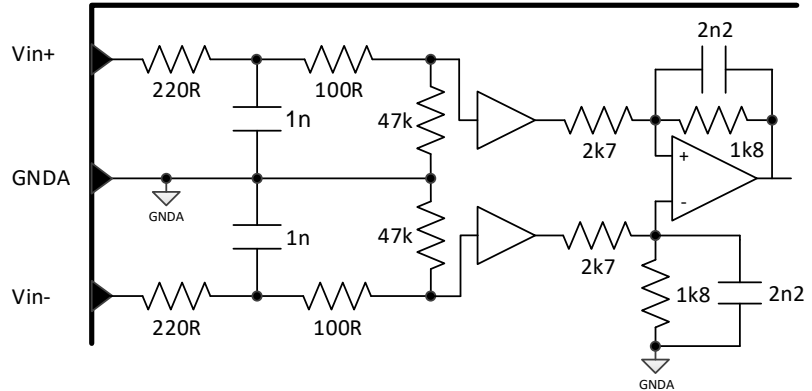

Figure 15: Balanced input buffer

Output Stage

The output stage is a full bridge topology with a 2nd order filter. The filter design is a part of ICEpower’s proprietary HCOM topology and has been chosen as the optimal solution between demodulation characteristics, efficiency and filter compactness. The essential output characteristics are:

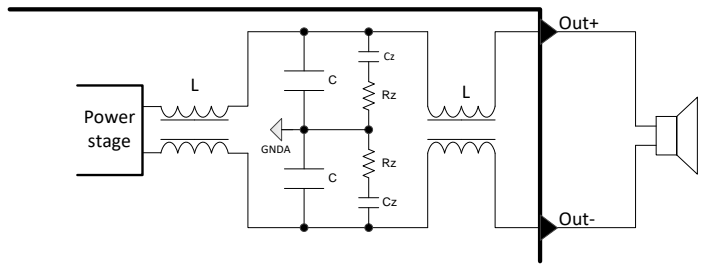

Figure 16: Output filter section with compensating Zobel network

- The switching residual on the output primarily consists of a single frequency component at the carrier fundamental f_s .
- The system bandwidth is 70 kHz in 4 Ω.

Over Current Monitor Pin

This pin is high (5 V) during normal operation but it is pulled low (0 V) if a short circuit is detected on the speaker output terminals. Other protection features such as Zobel protection and saturation detection also activate this pin. If any of these protection features are activated, the pin will be pulled low (0 V). This pin is output only.

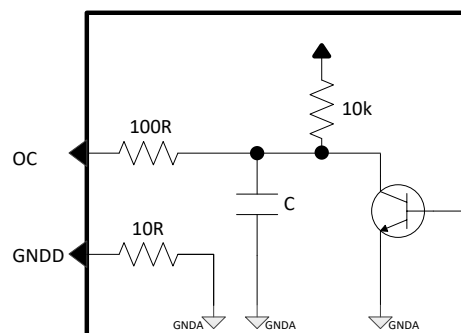

Figure 17: Over current monitor pin

Thermal Shutdown Pin

This pin indicates if the amplifier is shut down due to thermal overload. The pin is high (5 V) under normal conditions. If the amplifier temperature becomes too high, the amplifier shuts down and this pin is pulled low (0 V). This pin is only an output.

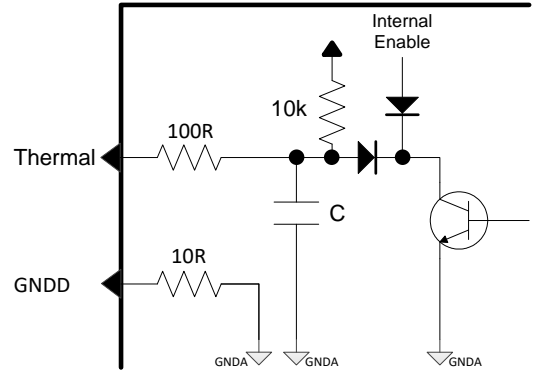

Figure18: Thermal protection pin interface.

Temperature Monitor Pin

This pin provides an analogue DC voltage representing the temperature sensed on the amplifier. This pin is only an output.

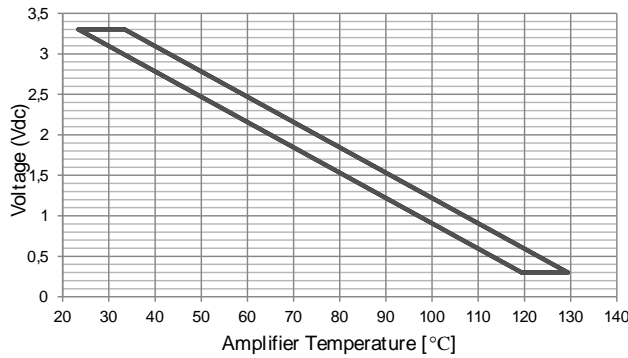

Figure 22: ICEpower700AS1 Temperature Monitor.

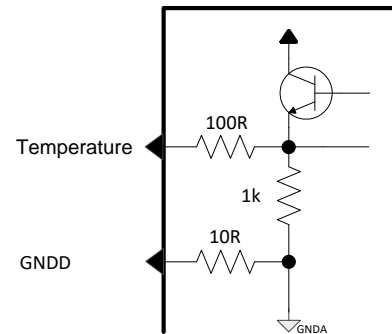

Figure 19: Temperature monitor pin interface.

Amplifier Enable

The Amplifier Enable pin can enable/disable the amplifier. If the pin is left unconnected, the level is high (5 V) and the amplifier is enabled. If the pin is pulled low (0 V) externally, the amplifier will be disabled. The enable pin is pulled low by the internal protection circuitry if the amplifier temperature becomes too high. This pin is bidirectional.

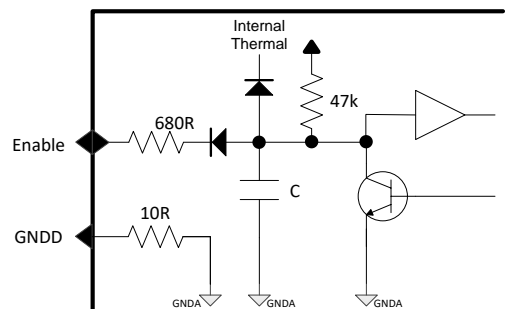

Figure 20: Amplifier enable pin interface.

Auxiliary Power Supply

The auxiliary supply can be used to power an external circuit such as a preamplifier or an equalizer/crossover. The maximum current draw from either +15 V or -15 V should never exceed 500 mA including the consumption from any connected hanger(s).

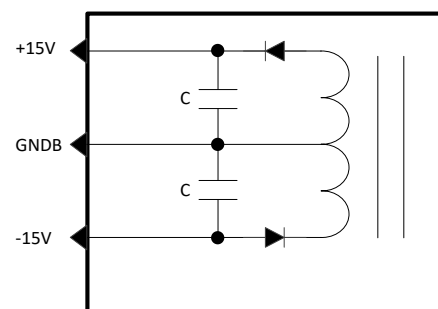

Figure 21: +/-15 V auxiliary supply

Hanger Vd

This high power DC output is only intended for powering stand-alone ICEpower amplifier modules like the ICEpower300A1. Maximum output power including the onboard ICEpower700AS1 amplifier output power is 700W.

Warning: The output is not short circuit protected. Continuous overload may permanently damage the power supply.

Trigger and Signal Sense

Three means are provided to put ICEpower700AS1 into Operational mode or Standby mode:

- 12 V trigger
- 3 V - 5 V trigger
- Signal Sense

The trigger levels are found in Table 18.

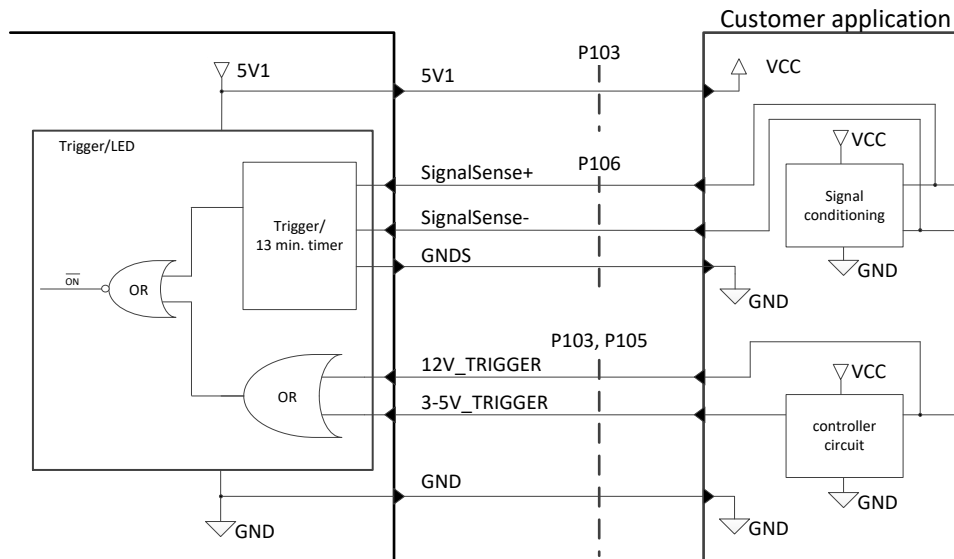

Figure 22: ICEpower700AS1 Trigger and Signal Sense connection scheme

The 12 V and 3 V - 5 V triggers are logic triggers. The 12 V trigger and the 3 V – 5 V trigger enable the designer to force operational mode by setting either one or both triggers high. Setting both logic triggers low will force standby mode (provided that no signal has been present at the Signal Sense terminals for at least 13 minutes).

Signal Sense

The Signal Sense function consists of an audio detection circuit and a timer. If an audio signal is present on the Signal Sense terminals, ICEpower700AS1 will enter operational mode. If audio is not present at the terminals, the timer will enter standby mode after approximately 13 minutes (provided that the logic triggers are set low).

LED Programming

ICEpower700AS1 features an onboard, programmable LED-driver for indication of operational- and standby-mode with eg. green and red LED's, respectively. The LED's are implemented in the application circuitry as shown in.

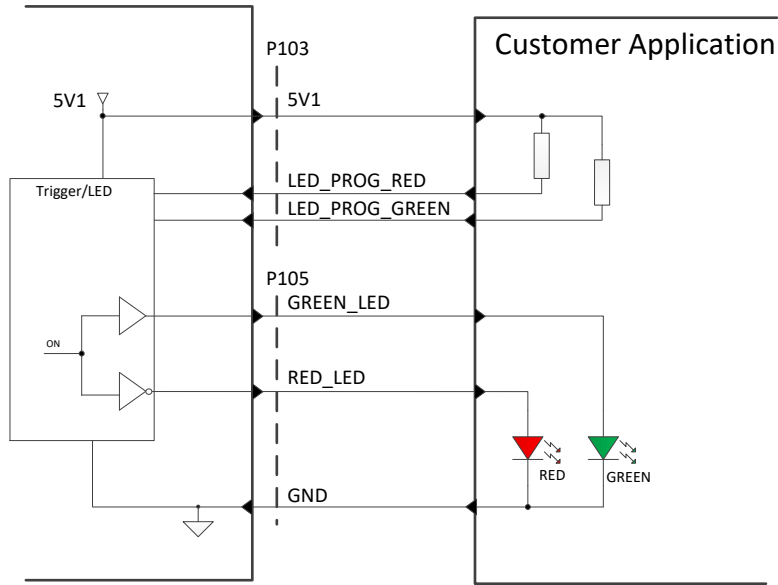

Figure 23: Application of the current programmable LED driver

The LED strength/current can be programmed individually by applying a resistor between the LED prog-pin and 5V1. The resistor values are selected according to the graph below.

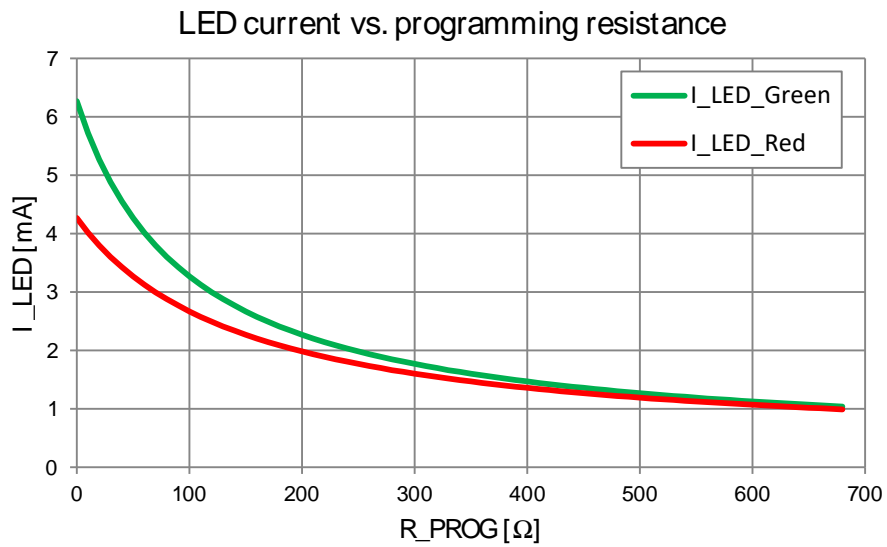

Figure 24: LED intensity/current programming

Operational Timing Diagrams

In the following sections, selected signals during power up/power down are illustrated.

Timing with Trigger input

From the timing diagram below, it is seen i.e. that the user will have 5V1 available 0.6 s after connecting 230 V mains and the user should wait at least 470 ms from trigger activation until current draw from 5V1 is increased above standby current level.

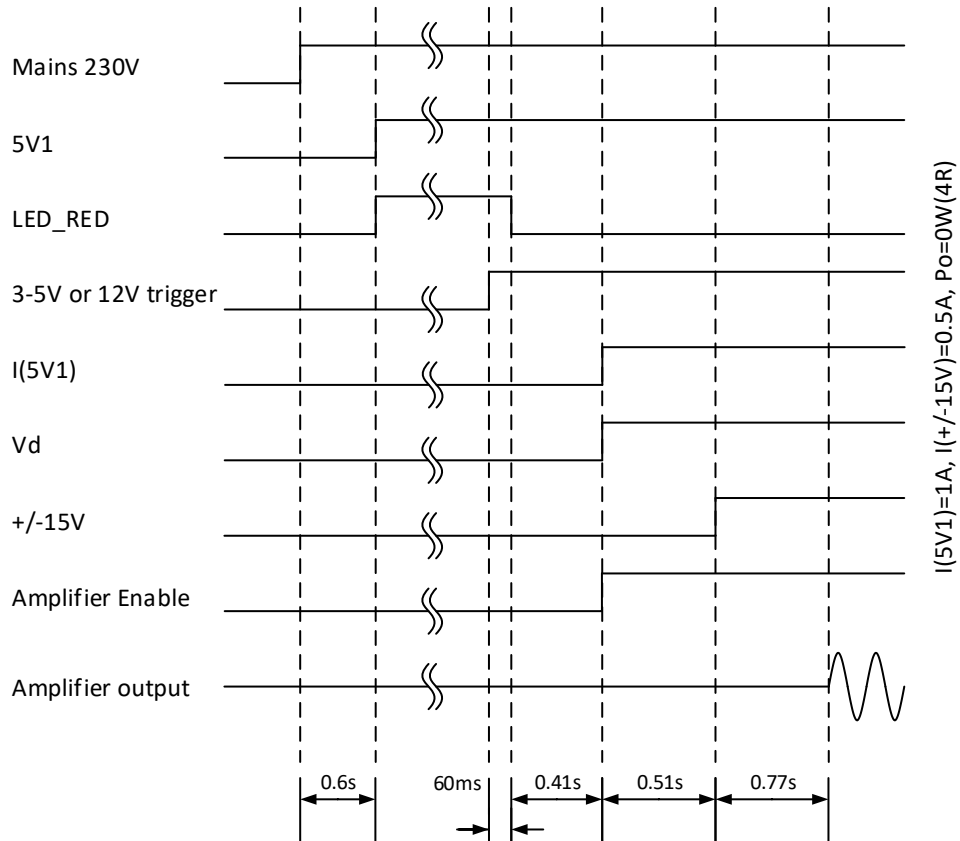

Figure 25: Power up from Mains on and trigger high, typical timing at 25 °C ambient.

From the timing diagram below, it is seen e.g. that the user should decrease current draw from 5V1 down to standby current level, no later than 60 ms from the point when the module is deactivated via trigger.

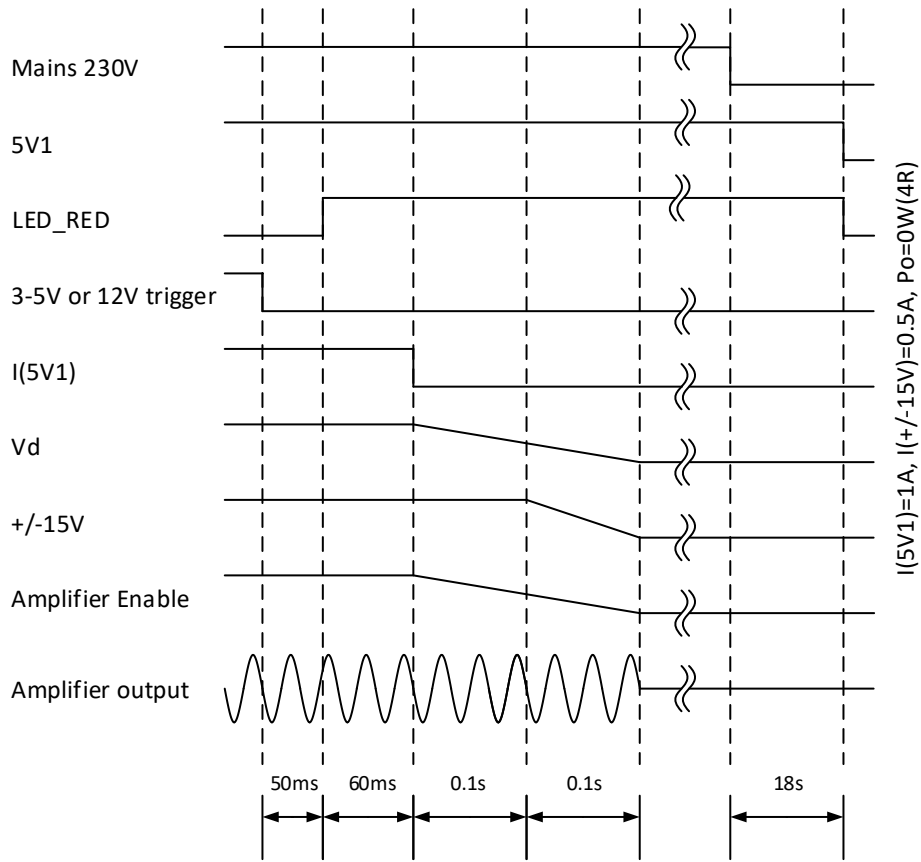

Figure 26: Power down from trigger low and Mains off, typical timing at 25 °C ambient.

Timing with Signal Sense

From the timing diagram below, it is seen e.g. that when the module is activated via Signal Sense, the user should wait at least 410 ms from LED_RED goes low, and until current draw from 5V1 is increased above standby current level. When the module deactivates and LED_RED goes high, the user has 4 s until current draw from 5V1 should be decreased down to standby current level.

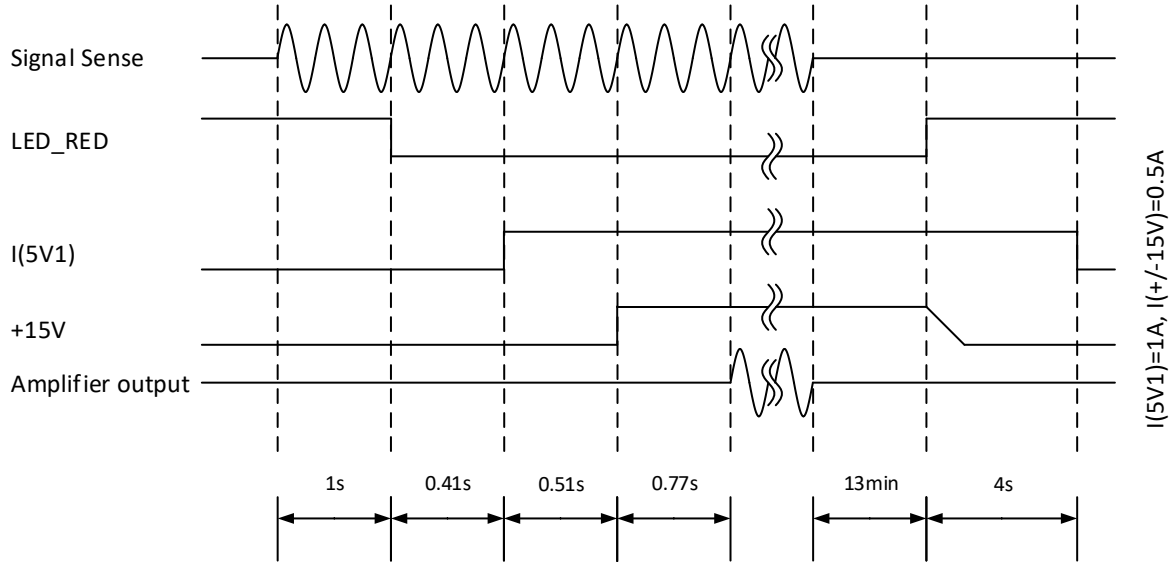

Figure 27: Power up/down on Signal Sense, typical timing at 25 °C ambient with 5mV, 100 Hz input signal.

Protection Features

Power Supply Protection

The power supply of the ICEpower700AS1 has two protection circuits: over temperature and over current.

The ± 15 V auxiliary outputs are over current protected.

The temperature protection is activated if the absolute temperature of the module is too high. This can be caused by high ambient temperature, high load (amplifier and AUX supply) for a long time or a combination of these two parameters.

Mains Over Voltage Protection

In the unlikely event of over voltage, the ICEpower700AS1 will disable the main power supply until set in standby mode by triggers or Signal Sense.

Amplifier Protection

The ICEpower700AS1 has a number of protection circuits.

These protection circuits handle over current protection, saturation detection, thermal protection and HF protection.

The over current protection circuit is divided into two parts. Pulse-by-pulse protection and loop saturation protection.

The pulse-by-pulse protection circuit limits the peak output current to 30 A.

The loop saturation protection circuit detects saturation of the control loop. This condition will typically be allowed for 100 ms to 500 ms which is enough to avoid accidental shutdown at peak currents during music output. This protects the amplifier against excessive heating during short circuits.

The over temperature protection will only occur if the P_{RMS} is greater than the specified Continuous Output Power. In normal use, the amplifier will not shut down if properly mounted.

The HF protection circuit protects the Zobel network against ultrasonic signals (greater than 20 kHz and at full power). This protection circuit has a built-in time constant so it is possible to deliver a high frequency, high amplitude signal for a short time.

Standby Converter

Overload Protection

The 5V1 output is protected against overload conditions. In the event of an overload or short circuit, the converter will reduce the output power, as illustrated in the figure below.

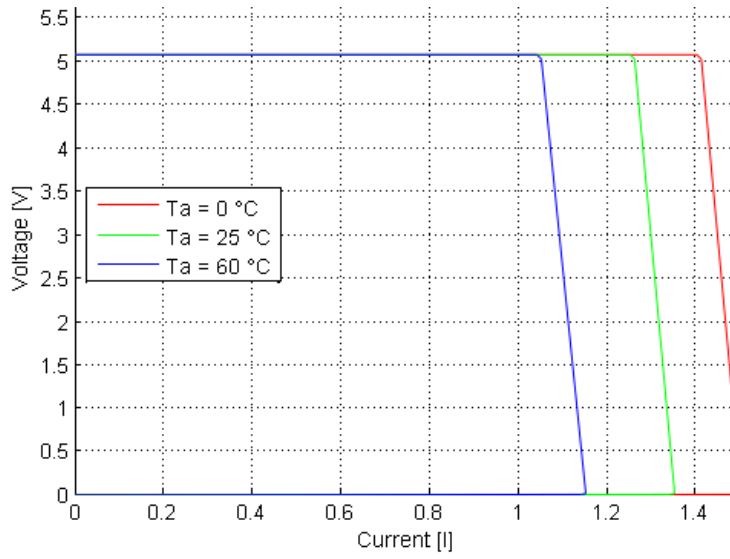

Figure 28: Typical 5V1 Overload Protection Voltage/Current curves

Input under Voltage

For safe operation, the standby converter prevents the system from starting up in case of AC-Line input below rating.

Thermal Protection

The standby converter is thermally protected. In the unlikely event of a temperature rise, the standby converter will shut down before reaching unsafe operating conditions and resume operation once the temperature has dropped to a safe level.

Integration Guideline

This section describes considerations in relation to module integration.

Typical Setup – Wiring diagram

The standalone ICEpower700AS1 configuration features one audio channel. By adding one or two amplifier hanger modules (ICEpower300A1), ICEpower700AS1 can be configured with up to three channels.

Below are illustrated two typical configurations of the ICEpower700AS1 module: A two channel and a three channel setup.

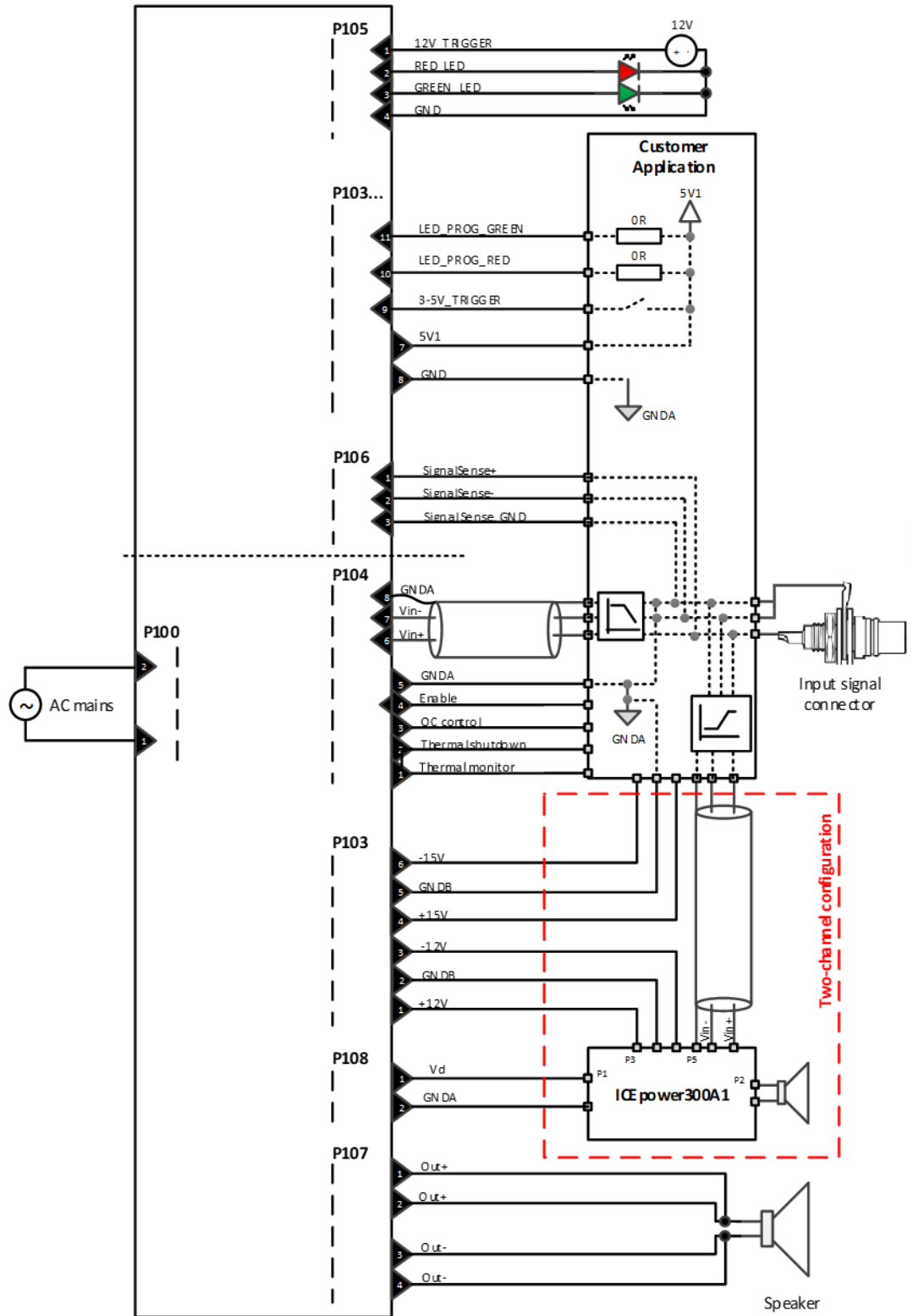

Figure 29: One and two channel configuration, Single Ended audio input

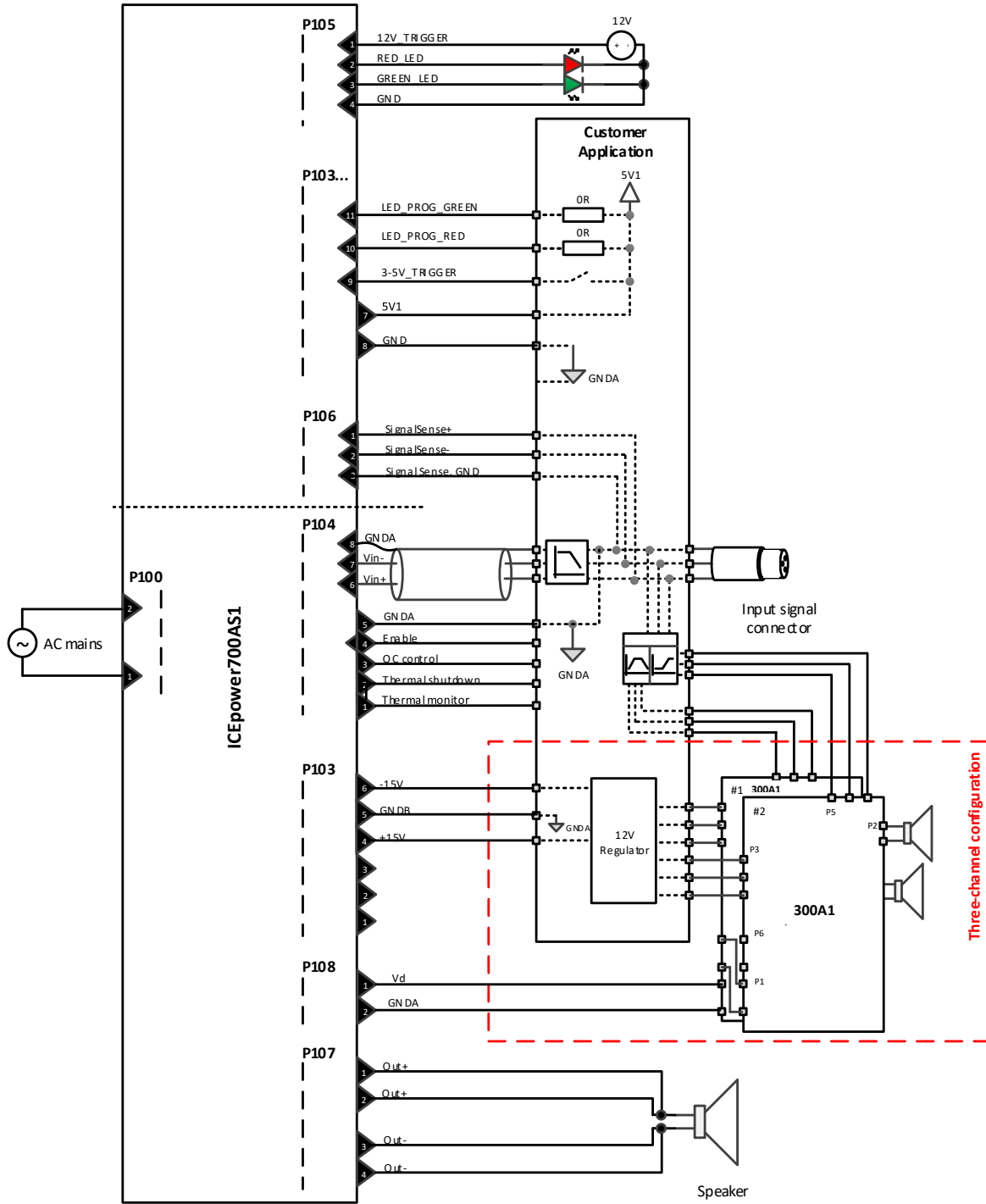

Figure 30: Three channel configuration, Balanced audio input

NOTE: In a three channel configuration the low voltage hanger supply must be derived from the ± 15 V which are regulated to ± 12 V on the Customer Application board.

Grounding Scheme

In order to avoid ground loops, ICEpower700AS1 implements ground segregation. These are named; <Signal Sense GND>, <GND>, <GNDA>, <GNDB> and <GNDD> and are illustrated in Figure.

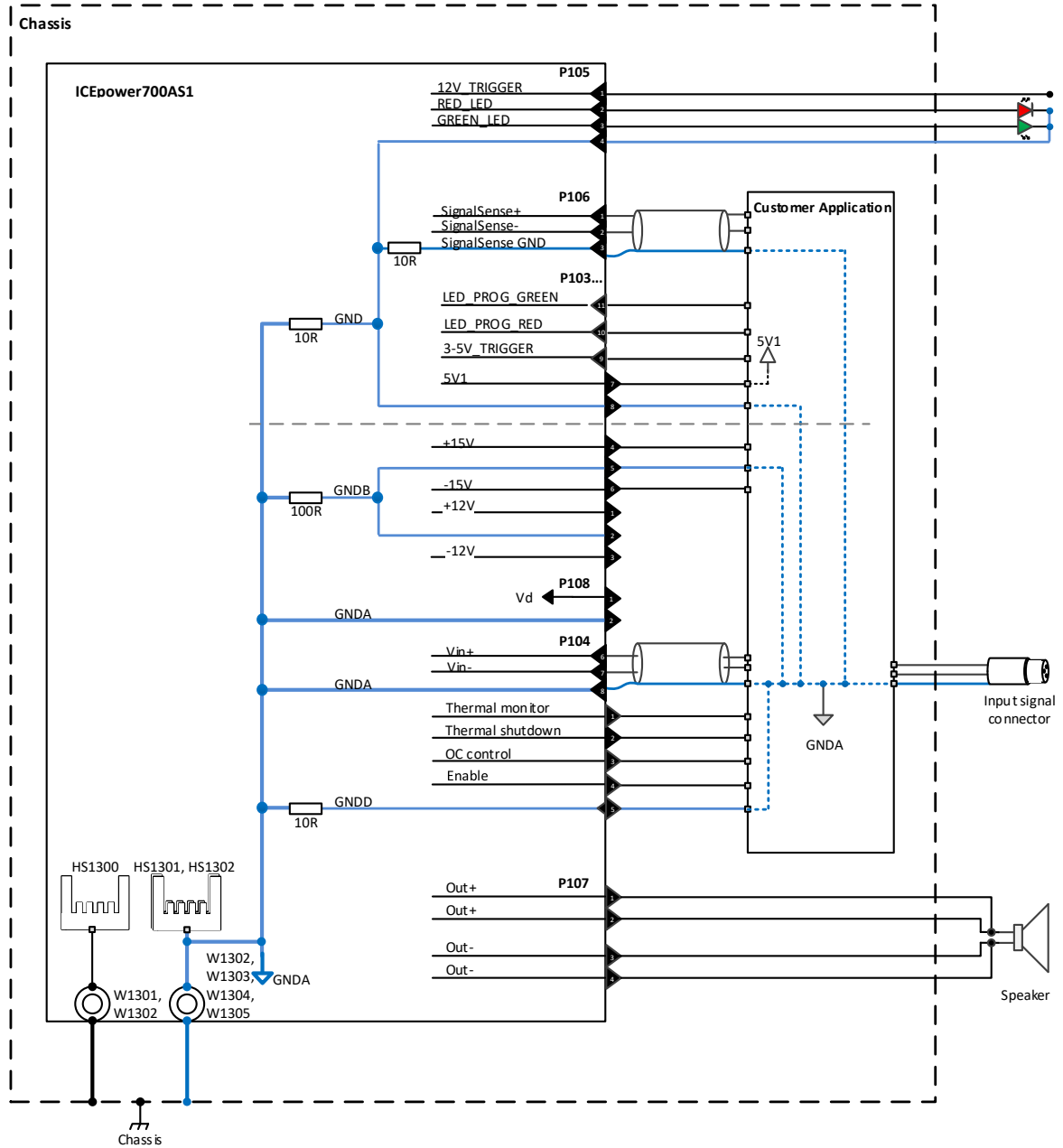

Figure 31: ICEpower700AS1 grounding scheme

To reduce the risk of hum, it is not recommended to connect GNDA directly to Chassis at the input signal connector

EMC management

General

ICEpower amplifiers and power supplies utilize the latest switching technology to offer intelligent, compact and efficient audio power conversion systems. However, operating fast switching signals generates unwanted high frequency noise. Unless the necessary design precautions are taken this noise may exceed the standardized EMC limits. This section describes some guidelines to help reduce emission.

ICEpower700AS1 complies to the required EMC standards. This reduces the challenge of gaining the final product EMC approval.

EMC Recommendations

- Loops conducting RF currents emit noise. It is important that speaker cables are twisted, shielded or at least run closely paralleled to reduce the loop area as much as possible. Always route speaker cables as close as possible to Chassis, in order to minimize the resulting ground loop. The same applies to mains and internal power supply cables as well as signal cables.

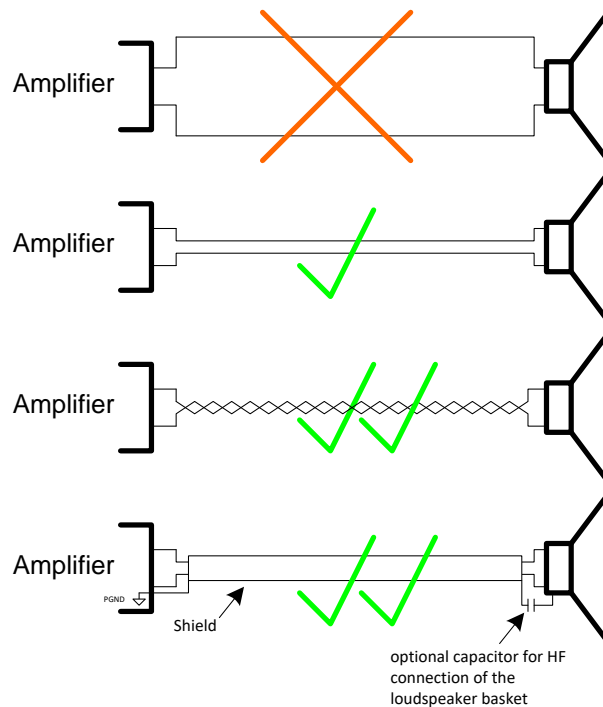

Note: When using shielded loudspeaker cable, the shield should not be connected directly to the basket of the loudspeaker. Loudspeakers may short the voice coil to the basket during heavy load resulting in damage to the module due to the short to ground. This can be avoided by making the connection to the basket through a capacitor.

- Do not route cables near the module magnetics.

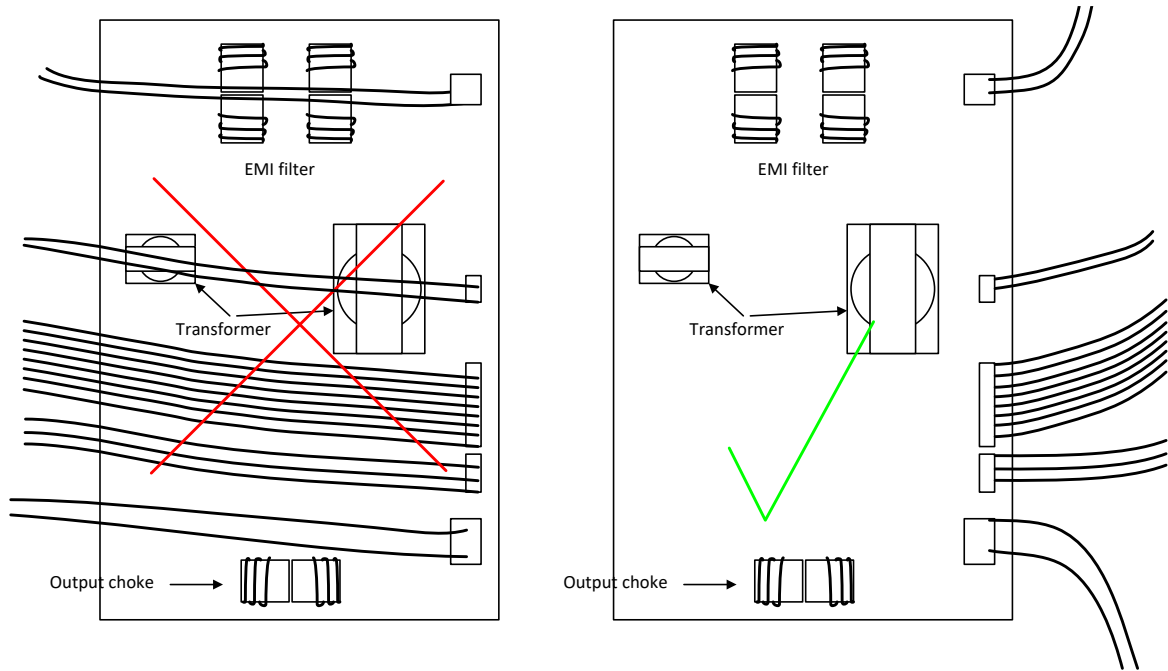

- Do not bundle input, output or mains cables.

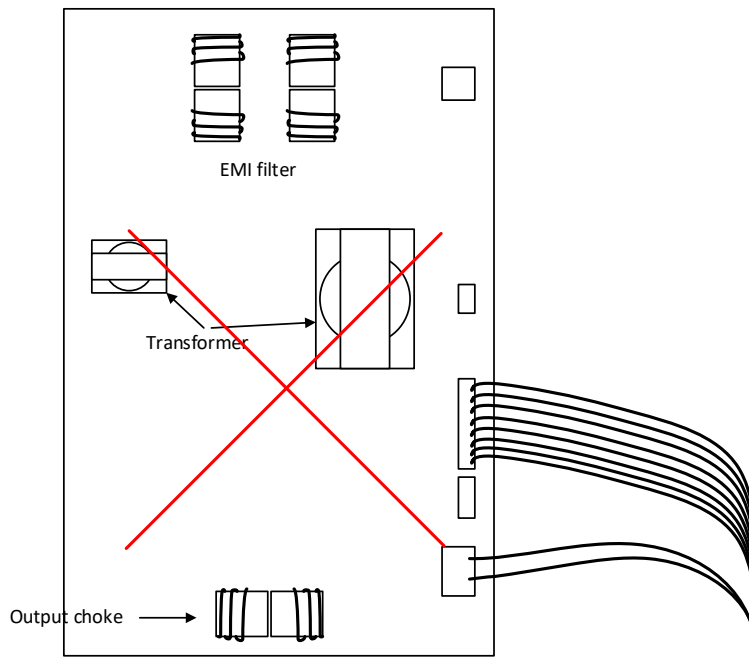

ICEpower has some basic recommendations, which should ease the EMC approval:

- When mounting via bottom side, the best EMC result is obtained when connecting all plated mounting holes to Chassis with low impedance spacers.
- When mounting via top side heat sinks, the best EMC result is obtained when connecting W200 and W201 to chassis with low impedance spacers.

If further reduction of emission is required, it is recommended to decouple all external wires to Chassis at the terminals, and GNDA on customer application board to Chassis.

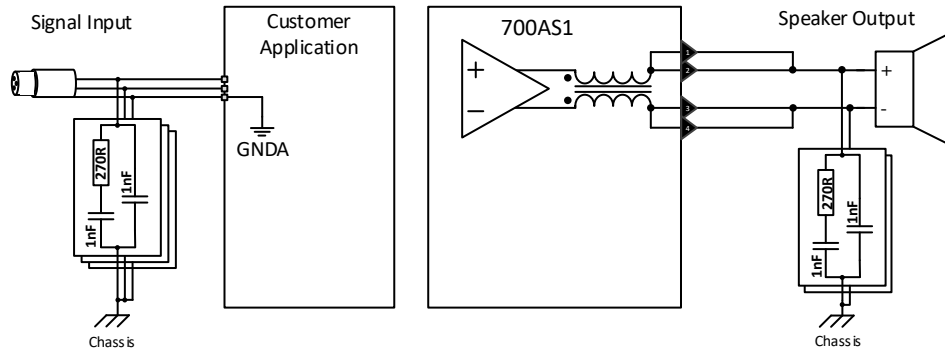

Figure 32: Illustration of decoupling of external wires for improved EMC performance

Thermal Design

ICEpower700AS1 implements high efficient ICEpower switching technology resulting in low losses.

ICEpower700AS1 is designed for high continuous power with no requirements for external heat sinking or fans.

However, if higher continuous power rating is required, external heat sinking can be connected directly to the onboard heat sinks. This eliminates the need for fans to the benefit of system robustness and cost.

Mechanical Mounting

The ICEpower700AS1 module is designed for mounting either on bottom side spacers or by the top side heat sinks.

Mounting on bottom side spacers

The module is mounted by means of 3.5 mm holes in the board. The holes are indicated on the illustration below.

12 mm spacers are recommended for mounting in order to ensure sufficient ventilation around the module and to ensure a proper safety clearance between module and chassis.

Drill Pattern

All dimensions are in [mm].

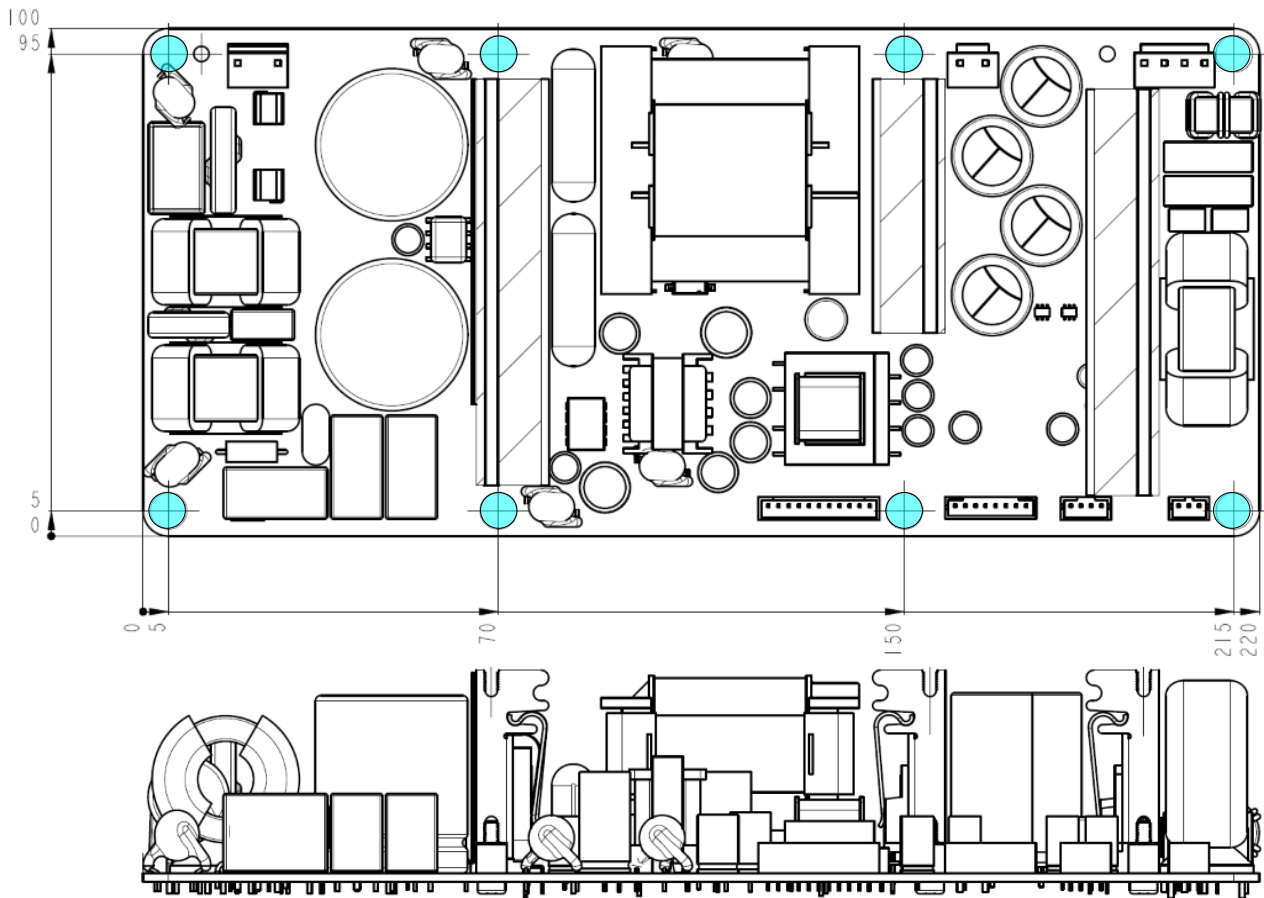

Figure 33: Mounting by bottom side spacers

Mounting by top side Heat Sinks

The ICEpower700AS1 is designed for flexible mounting and if needed easy mechanical interface to external heat-sinking for even higher continuous power capability.

The module should not be mounted solely by the heat sinks. Use 40 mm spacers for support in the positions marked cyan in Figure. Electrically conductive spacers must be used to comply with the EMC regulations.

On the bottom side of the PCB, 12 mm of space from PCB surface to Chassis is recommended for mounting in order to ensure sufficient ventilation around the module and to ensure a proper safety clearance between module and chassis.

Drill Pattern

All dimensions are in [mm].

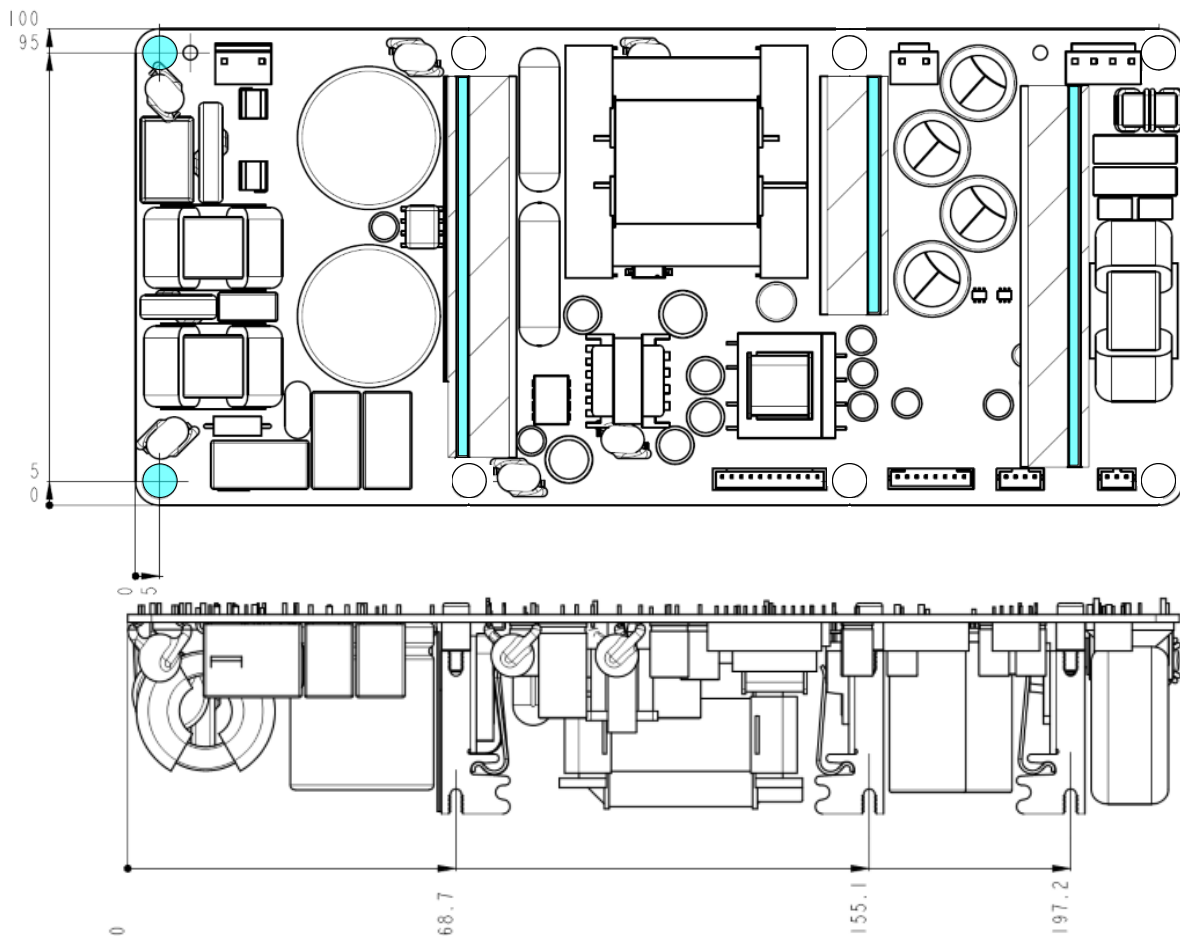
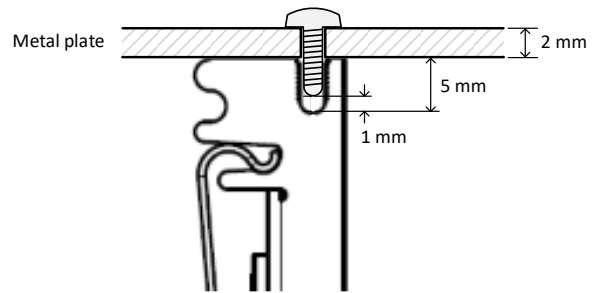

Figure 34: Mounting by top side Heat Sinks

The mounting slots in the top of the onboard heat sinks are designed for use with M3 DIN 7500 C thread forming screws. Thread forming screws (e.g. Bossard BN5653 M3) must be used in order to avoid burrs, which could cause unintentional short circuits.

The heat sink slot is approximately 5 mm deep. It is recommended to leave 1 mm slack for mechanical tolerances. I.e. to mount the module on a 2 mm plate, a $(5-1+2)$ mm = 6 mm screw is recommended.

A minimum of two screws in the 50 mm heat sink and three screws in the 80 mm heat sinks are recommended.



Standards

ICEpower700AS1 has been verified to conform to the following standards.

Safety

EN/IEC 62368-1:2018 (Second edition) &
EN/IEC 62368-1:2020 (Third edition)

UL 62368-1, 3rd Ed &
CAN/CSA C22.2 No. 62368-1:19, 3rd Ed

Audio/video, information and communication
technology equipment - Part 1: Safety
requirements

Audio/video, information and communication
technology equipment - Part 1: Safety
requirements

EMC

EN 55032:2012
(CISPR 32:2012)

Electromagnetic compatibility of multimedia
equipment – Emission requirements

EN 55020:2007 + A11:2011
(CISPR 20:2006)

Sound and television broadcast receivers and
associated equipment - Immunity
characteristics - Limits and methods of
measurement.

EN 61000-3-2:2006 + A1:2009 + A2:2009
(IEC 61000-3-2:2005 + A1:2008 + A2:2009)

Limits for harmonic current EMCssions
(equipment input current \leq 16 A per phase).

EN 61000-3-3:2008
(IEC 61000-3-3:2008)

Limitation of voltage changes, voltage
fluctuations and flicker in public low-voltage
supply systems, for equipment with rated
current \leq 16 A per phase and not subject to
conditional connection.

EN 61000-4-2:2009
(IEC 61000-4-2:2008)

Electrostatic discharge immunity test.

EN 61000-4-3:2006 + A1:2008 + A2:2010
(IEC 61000-4-3:2006 + A1:2007 + A2:2010)

Radiated, radio frequency, electromagnetic
field immunity test.

EN 61000-4-4:2004 + A1:2010
(IEC 61000-4-4:2004 + C1:2006 + C2:2007 +
A1:2010)

Electrical fast transient/burst immunity test.

CFR 47 part 15, subpart B, section 15.107(a)

Unintentional radiators, conducted limits.

CFR 47 part 15, subpart B, section 15.109(a)

Unintentional radiators, radiated EMCssion
limits.

ESD Warning

ICEpower products are manufactured according to the following ESD precautions:

- ANSI/ESD-S20.20-2007: Protection of Electrical and Electronic Parts, Assemblies and Equipment.

Further handling of the products should comply with the same standard.

The general warranty policy of ICEpower a/s does not cover ESD damaged products due to improper handling.

Packaging and Storing

ESD safe cardboard is used for wrapping:

Order Codes	Description	Part Number
ICEpower700AS1	1 × 700W ICEpower amplifier with integrated ICEpower supply, standby converter & universal mains operation.	8007646

Dimensions and weight:

Package	Quantity	Dimensions (w × d × h) [mm]	Gross Weight [kg]
Carton	18	390 × 580 × 240	26,5
Pallet	432	800 × 1200 × 1590	421

Storage Humidity and Temperature

Please refer to section Environmental Specifications page 10.

Stacking

Pallets may **not** be stacked on top of each other.

Contact

For additional information about the ICEpower® technology from ICEpower a/s, visit our web site or contact us.

ICEpower a/s
Vandtårnsvej 62A 3B
DK-2860 Søborg
Denmark

Phone +45 31 71 00 01

ICEpower.dk
info@icepower.dk

Legal Notes

ICEpower a/s believes that the information in this datasheet is accurate and reliable. However it is provided "as is" without any warranties of any kind. ICEpower a/s and its suppliers, to the fullest extent permitted by law, disclaim all warranties, including the warranty of merchantability, warranty of non-infringement of third-party rights, and the warranty of fitness for a particular purpose. ICEpower a/s and its suppliers make no warranties about the accuracy, reliability, completeness, or timeliness of the material, services, software, text, graphics and links. In no event will ICEpower a/s be liable to any party for any damages whether direct, indirect, special, consequential or other for any use or inability to use of this datasheet, including, without limitation, any damages for lost profits, business interruption, loss of programs or other data on your information handling system or otherwise, even if we are expressly advised of the possibility of such damages.

Information in this datasheet may contain technical inaccuracies or typographical errors. The information in the datasheet may be changed at any time without prior notice or obligation.

ICEpower® is a trademark of ICEpower a/s.

ICEpower a/s products are not authorized for use as critical components in life support devices or life support systems without the express written approval of the president and general counsel of ICEpower a/s. As used herein:

- Life support devices or systems are devices or systems which, (a) are intended for surgical implant into the body, or (b) support or sustain life, and whose failure to perform when properly used in accordance with instructions for use provided in the labelling, can be reasonably expected to result in a significant injury to the user.
- A critical component is any component of a life support device or system whose failure to perform can be reasonably expected to cause the failure of the life support device or system, or to affect its safety or effectiveness.

ICEpower a/s ©2020