

ICEpower a/s, Vandtårnsvej 62A, 3<sup>rd</sup> floor B, DK-2860 Søborg  
info@icepower.dk, www.icepower.dk



ICEpower Engine-400

# ICEbricks

## ICEpower Engine-400

Super Compact 400 W ICEpower Amplifier Module

# 1 Contents

1	CONTENTS .....	2
2	GENERAL DESCRIPTION .....	3
2.1	Key Specifications .....	3
3	DOCUMENT HISTORY .....	4
4	GETTING STARTED .....	5
5	BLOCK DIAGRAM .....	5
6	CONNECTION PINS .....	6
6.1	Engine-400 Connectors Overview .....	6
6.2	Connection pin specifications .....	6
7	ABSOLUTE MAXIMUM RATING .....	8
8	ELECTRICAL SPECIFICATIONS .....	8
8.1	Timing .....	9
9	MECHANICAL SPECIFICATION .....	10
9.1	Dimensions .....	10
9.2	Mounting Holes (move to connector section) .....	10
9.3	Environmental Specifications .....	10
10	TYPICAL PERFORMANCE CHARACTERISTICS .....	11
10.1	Frequency response .....	11
10.2	Typical performance measurement plots .....	11
10.3	Phase vs frequency .....	12
10.4	Output impedance .....	13
10.5	DIM30 3, 15kHz square wave + 15kHz sine wave vs power $4\Omega$ .....	13
10.6	THD+N vs frequency $4\Omega$ .....	14
10.7	CCIF 18+19kHz 1:1 $4\Omega$ .....	14
11	APPLICATION INFORMATION .....	15
11.1	EMC management .....	15
11.2	Power ON / OFF timings .....	15
12	ESD WARNING .....	16
13	ORDERING, PACKAGING AND STORAGE .....	16
13.1	Ordering information .....	16
13.2	Shipping dimensions and weight .....	16
13.3	Storage conditions .....	17
14	CONTACT .....	18
15	LEGAL NOTES .....	18

## 2 General Description

Engine-400 is a super compact class d amplifier module capable of delivering 400Wrms into 4 or up to 300Wrms into 8.

It is based on the patent pending Sierra modulation design which allows for constant loop gain in the audio band while still maintaining a first order closed loop response. Thereby the module shifts the phase less than 17 degrees in the audio band and allows for a -3dB point at 100 kHz.

Thanks to the Sierra modulation it also displays very low output impedance of less than 2mohm in the audio band. No heat sink is needed for playing music in 45 °C ambient and it is also straight forward to add heat sinking and achieve higher continuous output powers.

There are no components on the module which ages significantly. Instead, the product life time will be depending on choice of components surrounding the module.

Features	Benefits
Clip detect output signals high distortion	Allows the end-product system to proactively react, preventing system shutdown and enabling Music at All Times
Short circuit and over-current monitoring	Ensures reliable and robust end-products
Click-free disable input	
Convection cooling, no heat sink is needed	Easy thermal management
EMC pre-screened	Suitable for CE and FCC approved designs
Simple mounting through wave soldering	Easy mechanical integration
Over temp warning flag	Temp warning enables the customer to prevent shutdown by limiting or compression
Very low building height	Usable in 1U rack enclosures

### 2.1 Key Specifications

- 400Wrms into 4Ω
- 200Wrms into 8Ω (voltage limited)
- 300Wrms into 2Ω (current limited)
- 0,003% THD+N @ 1Wrms
- 25μVrms unweighted idle noise
- 124dB dynamic range
- <2mΩ output impedance in the audio band
- <17 degrees phase shift in the audio band
- <2,5W idle losses (1,8W in output stage)

### 3 Document History

Version	Date	Revised by	Changes
1.0	2016-02-09	PBM	First revision
1.1	2016-06-20	PBM	Thermal considerations added. 50Wrms/4Ω in 45°C ambient CCIF+DIM30 measurements added.
1.2	2017-08-29	DIT	Datasheet redesign
1.3	2022-11-24	LBH	Power ON / OFF timings added

## 4 Getting Started

The Engine-400 amplifier module is a single ended power amplifier capable of producing 400Wrms @ 1% THD+N into 4ohm. It is not a complete amplifier module though which means that some external parts are needed. Some of these are critical when it comes to characteristics but if a few pre-cautions are made it is quite straight forward to design a high-quality audio amplifier. 5 different supply rails are needed as with most class d amplifiers. The main rails provide the energy to the output stage. VA+/- supplies the internal OPAMP and some other discrete circuitry and VDR supplies the gate driver. It is important to apply VDR with caution as it is to supply the gate driver with +15V referenced to VS-. This means that this supply needs to be a positive voltage referenced to VS-, not a negative voltage referenced to GNDp.

The filter capacitor on the output has to have a certain value which can be found in the tables in this datasheet. The capacitors on the supply rails have to be able to handle a minimum of ripple current which can also be found in the tables. Make sure to place these capacitors close to the module as they contain high frequency currents.

The module starts without actively pulling DIS low (internally pulled down).

Further details around how to design an application around Engine-400 can be found in the application notes.

## 5 Block Diagram

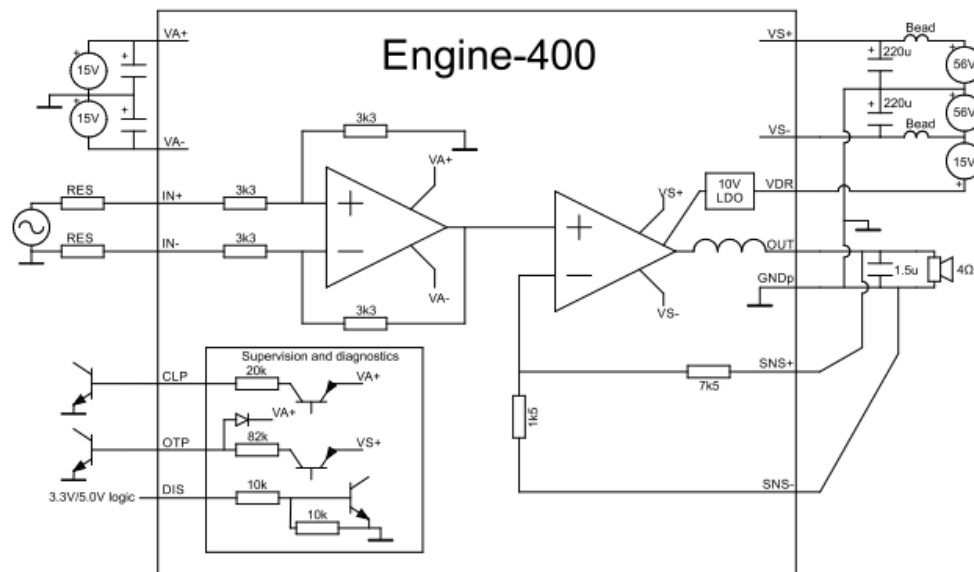

Figure 1: Engine 400 block diagram

## 6 Connection pins

Engine-400 comes with custom, massive brass pins. Their job is to hold the module to the motherboard and to distribute heat and current to the motherboard.

### 6.1 Engine-400 Connectors Overview

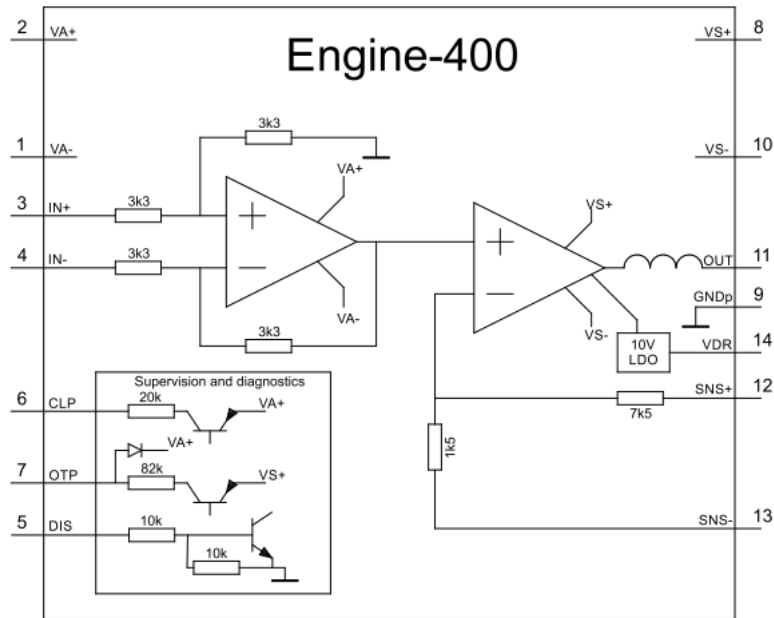

Figure 2: ICEbricks connector overview

### 6.2 Connection pin specifications

Custom surface treated copper pins			
PIN	Function	Description	Type
1	VA-	Negative supply for internal OPAMP and auxiliary circuitry. Should be well decoupled to minimize noise from entering the input circuitry.	Input
2	VA+	Positive supply for internal OPAMP and auxiliary circuitry. Should be well decoupled to minimize noise from entering the input circuitry.	Input
3	IN+	Positive input to differential receiver. Make sure that any series resistance connected to this pin is matched by an equal resistance to IN-.	Analog audio input
4	IN-	Negative input to differential receiver. Make sure that any series resistance connected to this pin is matched by an equal resistance to IN+.	Analog audio input
5	DIS	Disable input. Disables the amplifier when pulled high.	Control input
6	CLP	Clip detect collector output internally connected to VA+ and with 20kohm in series. Generates an instantaneous signal when the distortion exceeds approximately 0.1 % as during voltage clipping or current limiting. This signal can also be present when the amplifier is disabled if there is input signal applied.	Status output

7	OTP	Overtemp detect collector output internally connected to VS+ with 82kohm in series and clamped with a diode to VA+. Goes high when the temperature of the high side MOSFET exceeds approximately 103°C. Note that this is not an OTP shutdown, only a warning. The customer has to make sure that the amplifier is protected when this warning occurs.	Status output
8	VS+	Connection of positive supply voltage to the power stage. This pin will contain high frequency ripple so precautions must be made to minimize the impedance of the loop to VS- and GNDp through the use of high quality electrolytic capacitors.	Input
9	GNDp	Connection of system reference to the VS+/- decoupling capacitors.	GNDp
10	VS-	Connection of negative supply voltage to the power stage. This pin will contain high frequency ripple so precautions must be made to minimize the impedance of the loop to VS- and GNDp through the use of high quality electrolytic capacitors.	Input
11	OUT	Output signal pin. The output current with an overlapped high frequency tri-shaped current will flow out from this pin and the high frequency content has to be routed back to the system reference and GNDp as quickly as possible through high quality film capacitors. This node should be a fairly large copper area and GNDp must be a copper plane underneath this node. This is crucial to achieve low EMI and proper operation of the amplifier.	Audio power output
12	SNS+	Positive sense pin. Shall be connected to the output plane where the film capacitors are.	Analog audio input
13	SNS-	Negative sense pin. Shall be connected to the GND plane where the film capacitors are.	Analog audio input
14	VDR	Supply voltage for the internal gate driver. Referenced to VS-.	Input

Table 1: Connection pin specifications for Engine-400

## 7 Absolute Maximum Rating

Symbol	Parameter	Value	Unit
VS+	Positive rail voltage for the power stage. Referenced to GND.	+65	V
VS-	Negative rail voltage for the power stage. Referenced to GND.	-65	V
VA+	Positive rail voltage for the auxiliary circuitry. Referenced to GND.	+17	V
VA-	Negative rail voltage for the auxiliary circuitry. Referenced to GND.	-17	V
VDR	Gate drive voltage supply. Referenced to VS-.	+16	V
DIS	Disable input	+15	V
IN+	Positive audio signal input	+/-15	V
IN-	Negative audio signal input	+/-15	V
T <sub>A-max</sub>	Maximum ambient temperature <sup>1</sup>	55	C
T <sub>A-min</sub>	Minimum ambient temperature	0	C
C <sub>L</sub>	Maximum purely capacitive load	220	nF

Table 2 Absolute maximum ratings \*

Note1: When generating 50 W<sub>rms</sub> into 4Ω and without additional heat sink.

## 8 Electrical Specifications

Unless otherwise specified:

- Specifications are common to Engine-400
- f=1kHz, T<sub>A</sub>=25°C, VS+=+56V, VS-=-56V, VA+=+15V, VA-=-15V, VDR=+15V (to VS-)

Symbol	Parameter	Conditions	Min	Typ	Max	Unit
P <sub>out</sub>	Maximum output power at 1 % THD+N.	R <sub>load</sub> =8Ω		200		Wrms
P <sub>out</sub>	Maximum output power at 1 % THD+N.	R <sub>load</sub> =4Ω		400		Wrms
P <sub>out</sub>	Maximum output power at 1 % THD+N.	R <sub>load</sub> =2Ω (current limited)		300		Wrms
THD+N	THD+N in 4Ω	P <sub>out</sub> =1Wrms f=1kHz AES17 20kHz filter		0.002		%
THD+N	THD+N in 8Ω	P <sub>out</sub> =1Wrms f=1kHz AES17 20kHz filter		0.002		%
I <sub>VS</sub>	Quiescent current from VS+ to GND and VS- to GND	P <sub>out</sub> =0 R <sub>load</sub> =4Ω		16		mA
I <sub>VA+</sub>	Quiescent current from VA+ to GND	P <sub>out</sub> =0		17		mA
I <sub>VA-</sub>	Quiescent current from VA- to GND	P <sub>out</sub> =0		12		mA
I <sub>VDR</sub>	Quiescent current from VDR to VS-	P <sub>out</sub> =0		15		mA
I <sub>ripple</sub>	Ripple current at f <sub>sw</sub> flowing from VS+ to GND and VS- to GND	P <sub>out</sub> =50Wrms Measured with high frequency current probe		600		mA



$f_{sw}$	Switching frequency	$P_{out}=idle$ $R_{load}=4\Omega$		415		kHz
$V_{res}$	Switching residual	$P_{out}=idle$ $R_{load}=4\Omega$		700		mVrms
$V_{n,o}$	Output referenced idle noise	$R_{load}=4\Omega$ AES17 20kHz filter		25		$\mu$ Vrms
$A_v$	Voltage gain			15.3		dB
$f_u$	Upper -3dB limit	$R_{load}=4\Omega$		100		kHz
$f_l$	Lower -3dB limit	$R_{load}=4\Omega$ (usually limited by railpumping)		-		
$Z_o$	Output impedance	Output voltage measured when absorbing 1Arms		2		m $\Omega$
$Z_l$	Load impedance range	With suitable VS+ and VS- settings	2		12	$\Omega$
$V_{DC}$	DC voltage on output	$P_{out}=0$		5		mV
$I_{lim}$	Current limit threshold	$R_{load}=1\Omega$	19		22	Apk
$V_{OTP}$	Max output voltage from OTP pin	Measured with 1M $\Omega$ termination		+14.4		V
$I_{OTP}$	Max output current from OTP pin	Measured with current meter		0.5		mA
$V_{CLP}$	Max output voltage from CLP pin	Measured with 1M $\Omega$ termination		+14.8		V
$I_{CLP}$	Max output current from CLP pin	Measured with current meter		0.75		mA

Table 3 Audio performance

## 8.1 Timing

Symbol	Parameter	Min	Typ	Max	Unit
$t_{sd}$	Time from when all supplies are within range until the amplifier is operational	40	60	90	ms
$t_{md}$	Time delay from Disable to mute		0.1		ms
$t_{dmd}$	Time delay from Disable to operational	45	65	100	ms

Table 4 Timing specifications

## 9 Mechanical Specification

### 9.1 Dimensions

Symbol	Parameter	Condition	Min	Typ	Max	Unit
L	Module length			50		mm
W	Module width			30		mm
H	Module height				19,7	mm
Mass	Weight	Engine-400		35		g

Table 5: Mechanical dimensions

### 9.2 Mounting Holes (move to connector section)

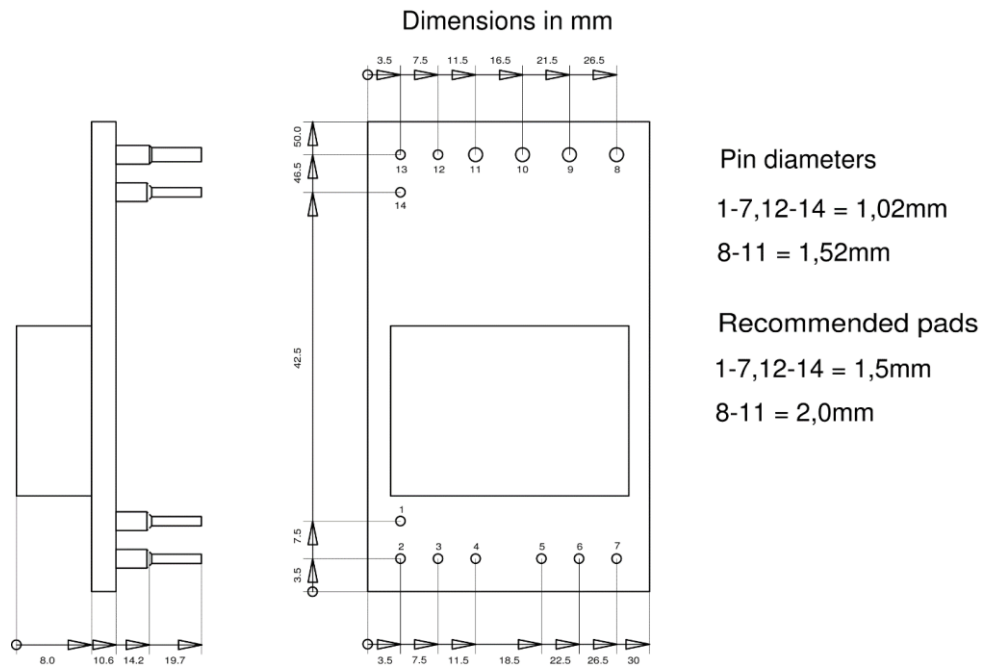

Figure 3: ICEbrick dimensions drawing and recommended pads for Engine-400

### 9.3 Environmental Specifications

Symbol	Parameter	Conditions	Min	Typ	Max	Units
T <sub>operating</sub>	Ambient temperature, operating		0		55	°C
T <sub>storage</sub>	Ambient temperature, storage		-40		TBD	°C
T <sub>shelf</sub>	Ambient temperature, shelf		0		TBD	°C
RH	Relative operating humidity	Non-condensing			TBD	%
	Relative storage humidity	Non-condensing			TBD	%
	Altitude, operating				2000	m

Table 6: Environment specifications

# 10 Typical Performance Characteristics

Typical performance data for Engine-400 are shown in the following graphs.

Measured in an adapter board with minimum recommended capacitances.  
Unless otherwise specified  $T_a = 25\text{ }^\circ\text{C}$ . Audio Precision AUX0025 and AES17 20 kHz filter.

## 10.1 Frequency response

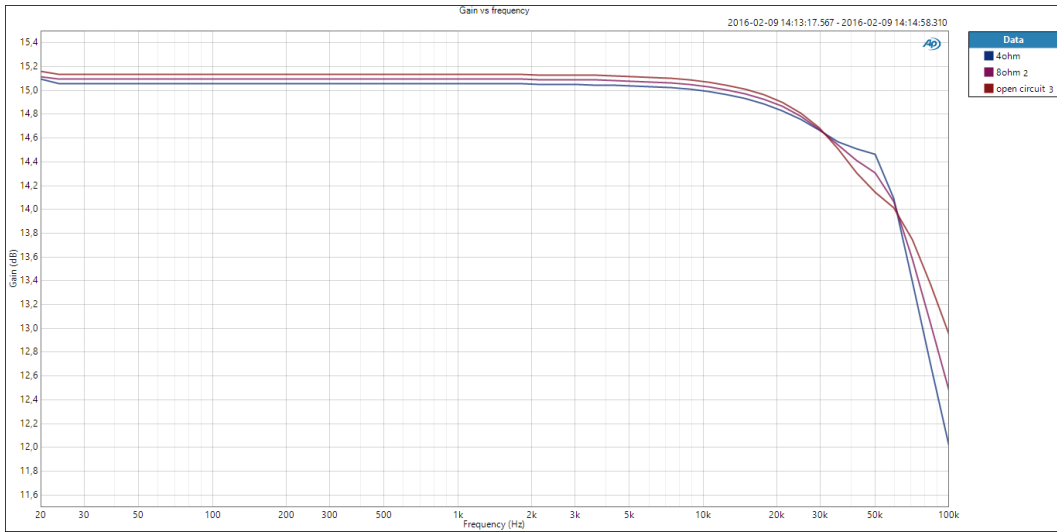

Figure 4: Amplitude vs frequency @  $R_L = 4\ \Omega$  (blue),  $R_L = 8\ \Omega$  (red) and open load (orange). Measured without AUX0025 filter.

## 10.2 Typical performance measurement plots

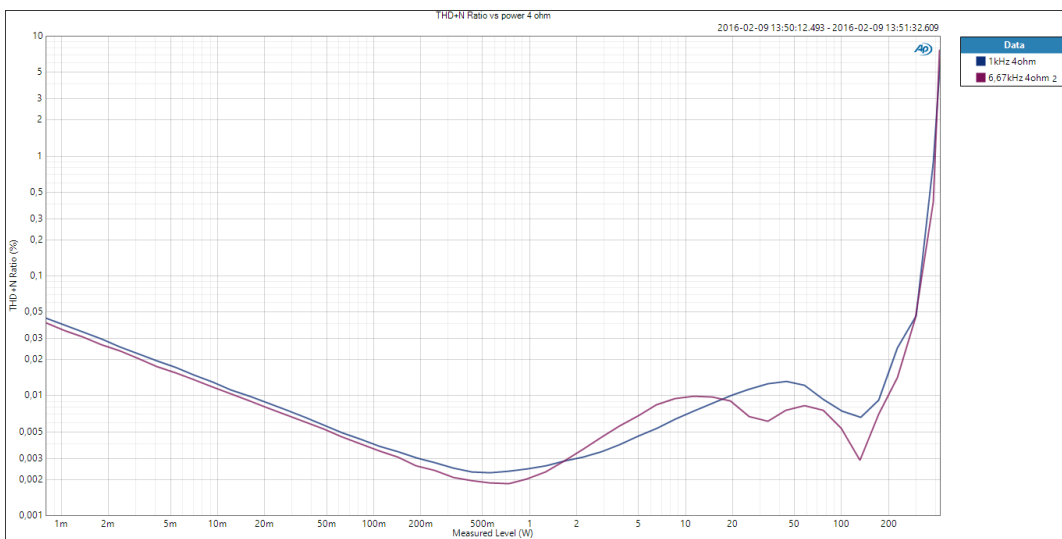

Figure 5: THD+N vs power @ 1kHz (blue), 6.66kHz (red),  $R_L = 4\ \Omega$

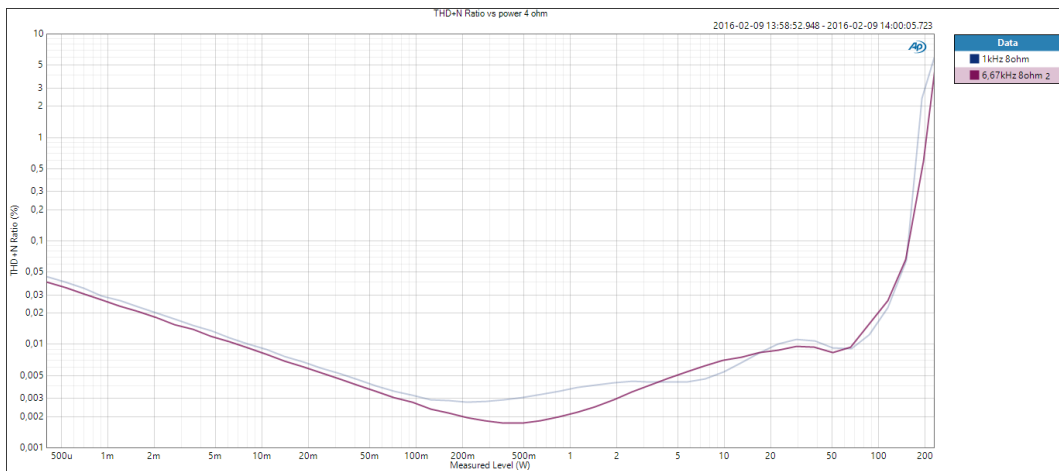

Figure 6: THD+N vs power @, 1kHz (blue), 6.66kHz (red),  $R_L = 8 \Omega$

### 10.3 Phase vs frequency

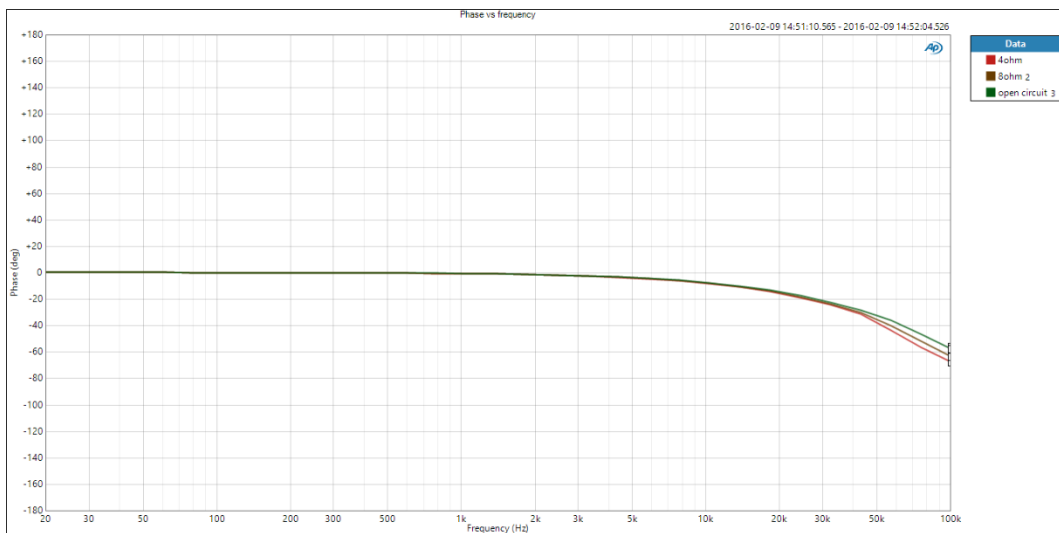

Figure 7 Phase vs frequency  $4\Omega$  (red),  $8\Omega$ (purple) and open load (green)

### 10.4 Output impedance

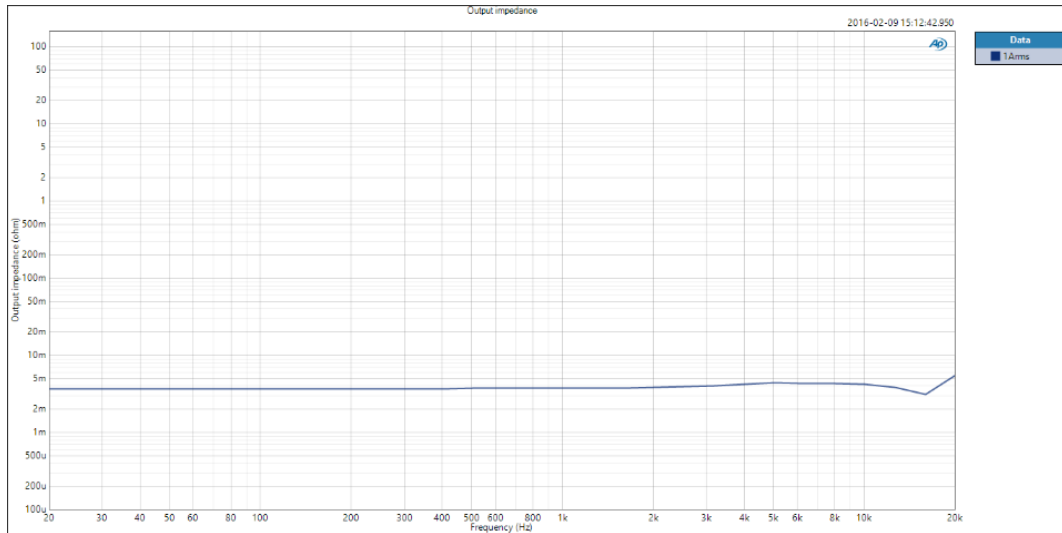

Figure 8 Output impedance. Measured as mV when dumping 1Arms into the output

### 10.5 DIM30 3, 15kHz square wave + 15kHz sine wave vs power 4Ω

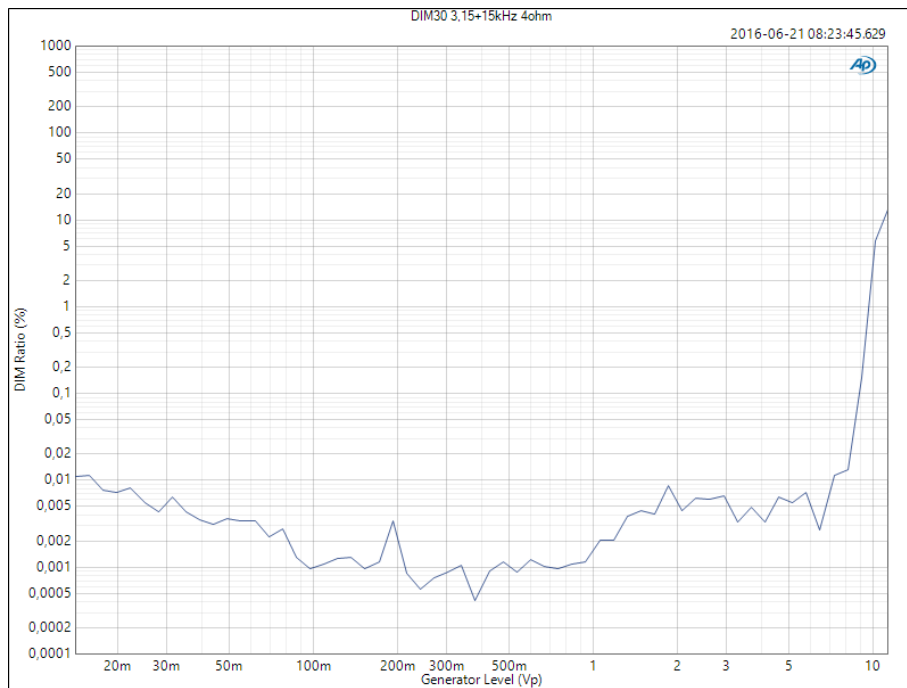

Figure 9 DIM30 3,15kHz+15kHz vs power 4Ω

### 10.6 THD+N vs frequency 4Ω

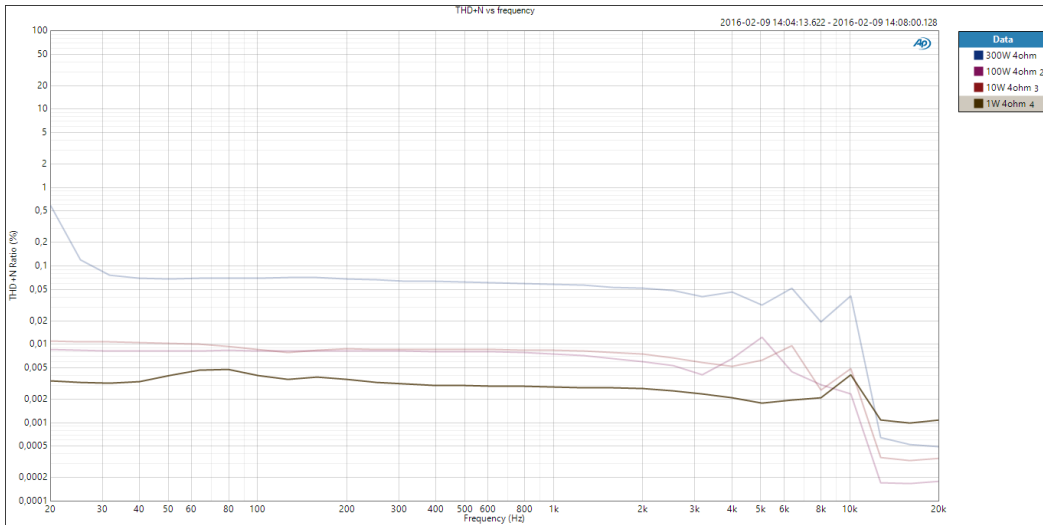

Figure 10 THD+N vs frequency 4Ω, 1W (green), 10W (red), 100W (purple) and 300W (blue)

### 10.7 CCIF 18+19kHz 1:1 4 Ω

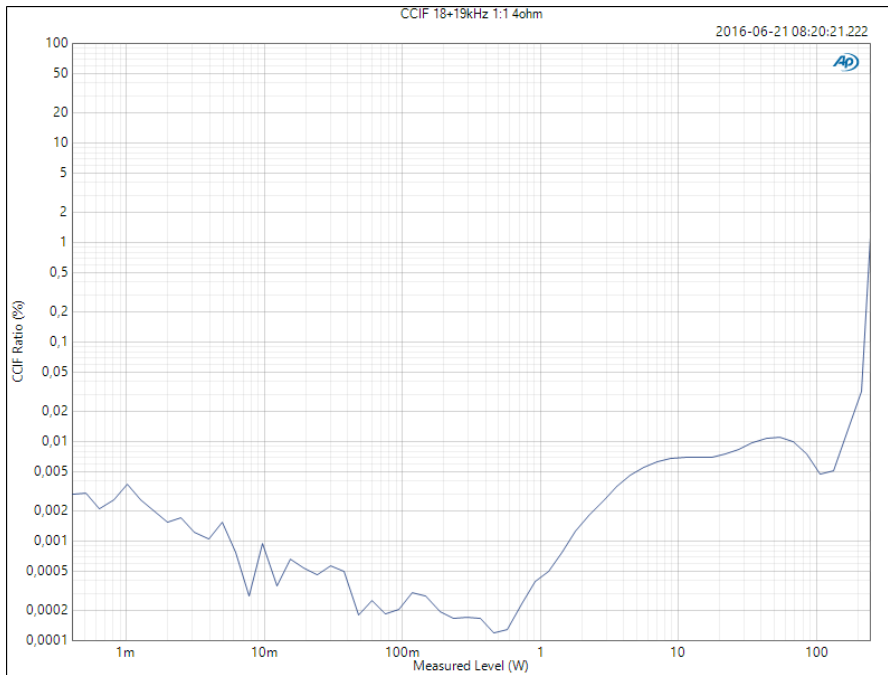

Figure 7: CCIF 18+19kHz 1:1 vs power 4Ω

# 11 Application information

See specification for Motherboard-1 for further application notes, recommended PCB design and instructions of use.

## 11.1 EMC management

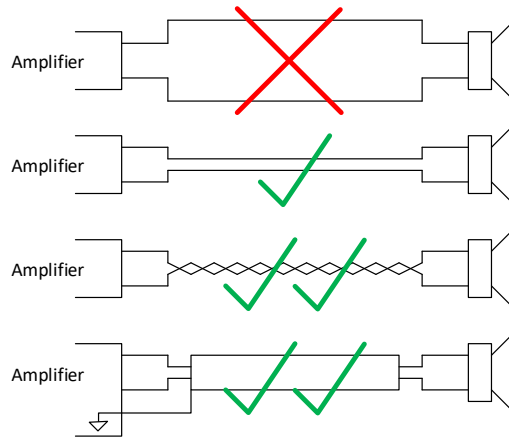

Figure 8: Speaker wire routing

## 11.2 Power ON / OFF timings

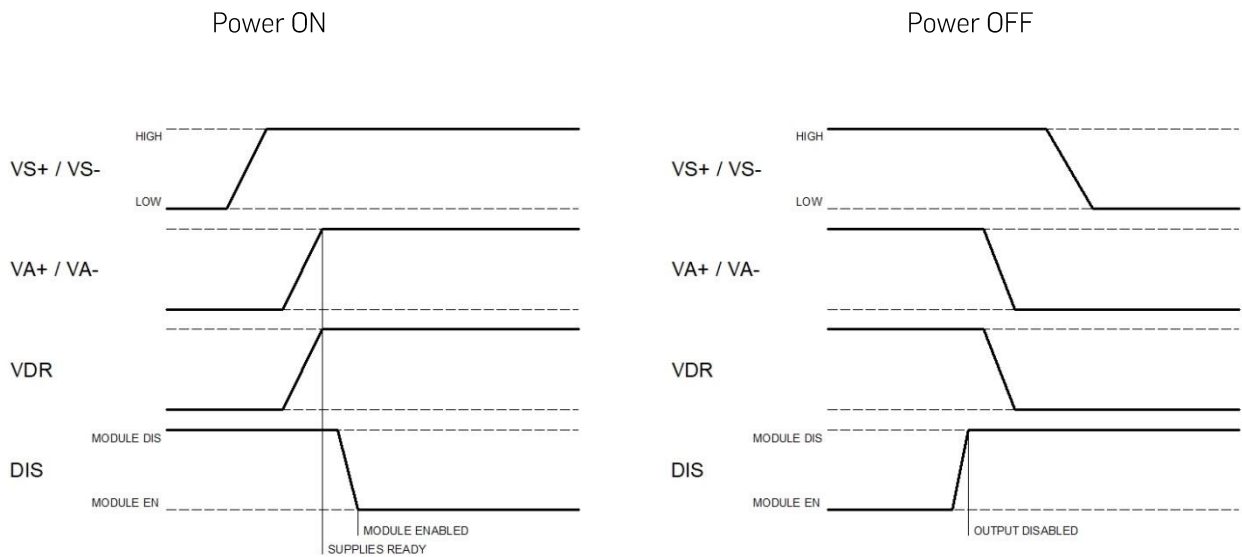

Figure 9: Timing diagrams, power ON / OFF

When powering ON the module first pull the DIS pin HIGH, disabling the module and then VS+ / VS- should reach steady ON (HIGH), followed by turning on VA+ / VA- and VDR. VA+ / VA- can also be turned on before or after VDR just as long VS+ / VS- are ON/ high first. When VS+ / VS-, VA+ / VA- and VDR have reached steady ON (HIGH), the module DIS pin may be pulled LOW, to enable the module.

When powering OFF the module, first pull module DIS pin HIGH, to disable the module. Then turn off VA+ / VA- and VDR (VA+ / VA- can also be turned off before or after VDR). When VA+ / VA- and VDR reach steady OFF (LOW), VS+ / VS- may be turned off.

## 12 ESD warning

ICEpower products are manufactured according to the following ESD precautions:

- ANSI/ESD-S20.20-2007: Protection of Electrical and Electronic Parts, Assemblies and Equipment.

Further handling of the products should comply with the same standard.

The general warranty policy of ICEpower a/s does not cover ESD damaged products due to improper handling.

## 13 Ordering, Packaging and Storage

All ICEpower modules are packaged in ESD safe bobble bags and cardboard boxes.

### 13.1 Ordering information

Order Codes	Description	Part Number
ICEpower Engine-400	Super Compact 400 W ICEpower Amplifier Module	8004001

### 13.2 Shipping dimensions and weight

Package	Quantity	Dimensions (w × d × h) [mm]	Gross Weight [kg]
Carton	54 Modules	570 × 380 × 110	2.3
Pallet	40 Cartons	1200 × 800 × 1350	92



### 13.3 Storage conditions

#### Storage Humidity and Temperature:

Please find storage humidity and temperature information in Section 9.3, Environmental Specifications.

#### Stacking

Pallets may not be stacked on top of each other.

## 14 Contact

For additional information about the ICEpower® technology from ICEpower a/s, visit our web site or contact us.

ICEpower a/s  
Vandtårnsvej 62A, 3rd floor B  
DK-2860 Søborg  
Denmark

[www.icepower.dk](http://www.icepower.dk)  
[info@icepower.dk](mailto:info@icepower.dk)

## 15 Legal Notes

ICEpower a/s believes that the information in this datasheet is accurate and reliable. However, it is provided "as is" without any warranties of any kind. ICEpower a/s and its suppliers, to the fullest extent permitted by law, disclaim all warranties, including the warranty of merchantability, warranty of non-infringement of third-party rights, and the warranty of fitness for a particular purpose. ICEpower a/s and its suppliers make no warranties about the accuracy, reliability, completeness, or timeliness of the material, services, software, text, graphics and links. In no event, will ICEpower a/s be liable to any party for any damages whether direct, indirect, special, consequential or other for any use or inability to use of this datasheet, including, without limitation, any damages for lost profits, business interruption, loss of programs or other data on your information handling system or otherwise, even if we are expressly advised of the possibility of such damages.

Information in this datasheet may contain technical inaccuracies or typographical errors. The information in the datasheet may be changed at any time without prior notice or obligation.

ICEpower® is a trademark of ICEpower a/s.

ICEpower a/s products are not authorized for use as critical components in life support devices or life support systems without the express written approval of the president and general counsel of ICEpower a/s. As used herein:

- Life support devices or systems are devices or systems which, (a) are intended for surgical implant into the body, or (b) support or sustain life, and whose failure to perform when properly used in accordance with instructions for use provided in the labelling, can be reasonably expected to result in a significant injury to the user.
- A critical component is any component of a life support device or system whose failure to perform can be reasonably expected to cause the failure of the life support device or system, or to affect its safety or effectiveness.

ICEpower a/s ©2016